

TC·HELICON®



VOICELIVE 2

USER'S MANUAL

Ver. 1.3

WARNING

To reduce the risk of fire or electric shock, do not expose this appliance to rain or moisture.

CAUTION

This equipment has been tested and found to comply with the limits for a Class B digital device pursuant to Part 15 of FCC Rules. Operation is subject to the following two conditions: (1) This device may not cause harmful interference, and (2) this device must accept any interference received, including interference that may cause undesired operation.



The lightning symbol within a triangle means, "Electrical caution!" It indicates the presence of information about operating voltage and potential risks of electrical shock.



The exclamation point within a triangle means, "Caution!" Please read the information next to all caution signs.

Table of Contents: Basics Section

Introduction	7	<i>Using The Effect On/Off Switches</i>	19
Front Panel	9	<i>The SHORTCUT Footswitch</i>	19
Back Panel	12	<i>The STEP Footswitch</i>	20
Quick Start	14	<i>Programming Your Own Steps</i>	20
<i>Overview</i>	14	<i>Tone, Pitch And Guitar FX Buttons</i>	21
<i>Step 1: Pre-Flight Check</i>	14	<i>Activating Bypass + Tuner Mode</i>	22
<i>Step 2: Inputs</i>	15	<i>Changing The Mix</i>	22
<i>Step 3: Outputs</i>	16	<i>Basic Editing Concepts</i>	23
<i>Step 4: Set Mic Level</i>	17	VoiceLive 2 for the Guitarist/Singer	24
<i>Step 5: Quick Start Settings</i>	17	<i>Overview</i>	24
First Impressions	18	<i>Acoustic Guitar</i>	24
<i>How To Audition Presets</i>	18	<i>Electric Guitar</i>	25
<i>Finding Presets With The Wizard</i>	18	<i>Tuning Your Guitar</i>	25
<i>Using Harmony Presets</i>	18	<i>Guitar Performance Tips</i>	25

Table of Contents: Basics Section

<i>VoiceLive 2 for the MIDI keyboardist/Singer</i>	26	<i>The USB Connection</i>	32
<i>Overview</i>	26	<i>The VoiceSupport Application</i>	32
<i>MIDI Hookup And Channel Selection</i>	26	<i>VoiceLive 2 And Digital Audio</i>	33
<i>MIDI IN And USB</i>	26	<i>USB Audio And ASIO Applications</i>	35
<i>MIDI Controlled Harmony</i>	26	<i>Selecting The Audio Device</i>	35
<i>MIDI Performance Tips</i>	27	<i>USB and MIDI Control</i>	35
<i>Alternate Harmony Method</i>	27		
<i>VoiceLive 2 for the Lead Singer</i>	28		
<i>Overview</i>	28		
<i>Using A Fixed Key (aka “Scale”)</i>	28		
<i>Singing To Music Playback</i>	29		
<i>“Borrowing” From Another Player</i>	30		
<i>General Usage Tips</i>	31		
<i>Connecting VoiceLive 2 To A Computer</i>	32		

Table of Contents: Details Section

The Tone Button	38	<i>The EQ Tab</i>	51
<i>The Tone Tab</i>	38	<i>The Compress Tab</i>	52
<i>The Adaptive Check Boxes</i>	39	The Edit Menu Overview	53
<i>The Shape Control</i>	39	<i>The μMod Tab</i>	54
<i>The Compress Control</i>	40	<i>The Delay Tab</i>	57
<i>The De-Ess Control</i>	41	<i>The Reverb Tab</i>	60
<i>The Gate Control</i>	42	<i>The Harmony Tab</i>	63
<i>The EQ Tab With Adaptive On</i>	42	<i>The Double Tab</i>	72
<i>The EQ Tab With Adaptive Off</i>	43	<i>The FX Tab</i>	74
<i>The Compress Tab With Adaptive On</i>	45	<i>The Rhythmic Tab</i>	79
<i>The Compress Tab With Adaptive Off</i>	45	<i>The Preset Tab</i>	82
<i>The Gate Tab</i>	46	The Setup Menu	83
The Pitch Button	48	<i>I/O Tab</i>	83
The Guitar FX Button	49	<i>The MIDI Tab</i>	86
<i>The Guitar FX Tab</i>	49		

Table of Contents: Details Section

<i>The System Tab</i>	88
<i>The Expression Tab</i>	89
<i>The VLoop Tab</i>	91
<i>The Store Menu</i>	93
<i>FAQ and Troubleshooting</i>	94
<i>MIDI Implementation</i>	98
<i>Factory Preset List</i>	101
<i>Effects Path Diagram</i>	103
<i>Warranty</i>	104
<i>Specifications</i>	105

Welcome to VoiceLive 2

Thank you for stepping into the evolution of what it means to be a singer. VoiceLive 2 was conceived and engineered during a time in history when singers took control of their vocal sound with the advent of vocal effects pedals and rack mount units. The significance for you, the singer using VoiceLive 2, is being able to benefit from a wave of innovation that makes production of your vocal sound effortless and creative.

We encourage you to give a quick scan of the Quick Start and First Impressions section. You likely don't need much help getting started with VoiceLive 2, but these sections can help you get the most from VoiceLive 2 and your voice. Also, please install the VoiceSupport application from the CD in your product's packaging. This web-enabled application connects you to the latest updates, tips and tricks for your VoiceLive 2.

Features:

- o Stompbox access to six effect blocks
- o Easy editing of all parameters
- o Simple effect chaining with Step feature
- o Control harmonies with guitar, MIDI or MP3 input
- o Up to 8 voices of new NaturalPlay harmonies
- o New reverb, delay, μ Mod, and double
- o FX block for HardTune, megaphone, distortion
- o Global tone, correction, and guitar effects
- o Digital mic-gain control is engaged by your feet
- o USB for updates, back-ups and audio streaming

Introduction

About TC-Helicon

At TC-Helicon we truly believe that the voice is the world's most beautiful instrument. We don't mean to degrade other beautiful instruments, but the singing voice is the anthropological source for all things melodic.

You should know there is a dedicated group of engineers, researchers and product specialists based in Victoria BC, Canada, who spend every waking moment of their working lives listening, talking, singing, and interacting with singers and those who have passion for the singing voice.

All this knowledge and experience is used to design products respecting and empowering the modern vocalist. Our products focus on removing barriers and inspiring creativity in performance. That's why our products range from near-field personal vocal monitors to floor-based vocal multi-effects pedals.

Enjoy!

The TC-Helicon Team

About This Manual

You've no doubt noticed that the Table of Contents has two sections: the Basics section and the Details section. This manual is divided into sections so that users who prefer to get right into using the product can do so quickly with a minimum of detailed text. Users who want to learn the detailed operation of every parameter can use the Details section.

Product Firmware Version

Feature descriptions in this manual represent VoiceLive 2 firmware version 1.2 and newer. Product version is temporarily visible when the product is powered on. You can check for the latest firmware version by running the VoiceSupport application and checking the items in its HOME tab.

Front Panel



Front Panel

1. GLOBAL GROUP - When activated, these three effects stay on independent of preset changes. Press any to activate or hold to enter a specific edit menu. **TONE** applies EQ, compression and more to improve the core sound of your voice. **PITCH** adds subtle, chromatic pitch correction to help you sing more in tune. Press **GUITAR FX** to add modulation and reverb effects to the guitar connected to the GUITAR IN jack. The GUITAR THRU jack must be empty for GUITAR FX to be heard.

2. HOME - Press this to return to the main performing mode from SETUP, WIZARD, STORE or EDIT modes.

3. MAIN DISPLAY - All text and graphics feedback is shown here. The Contrast adjustment is in the SYSTEM tab of the SETUP menu.

4. SETUP - Press this to access the I/O, MIDI, SYSTEM and EXPRESSION pedal edit tabs.

5. WIZARD - This helps you find presets on the basis of factory-assigned tags or to sort alphabetically by name.

6. STORE - Press to enter a menu to name, assign a

destination and commit edited presets to memory. To cancel and exit, press HOME.

7. EDIT - Press to enter EDIT menu and make changes to the μ MOD, DELAY etc effects parameters via their tabbed menus. HOME exits EDIT mode.

8. MIX / EDIT - When HOME is lit, turning any of these will temporarily present the MIX screen allowing control of the relative levels of the VOICES (harmony and doubling), DELAY/REVERB, GUITAR and OUTPUT level. In EDIT mode, these controls adjust the highlighted parameters immediately above them.

9. NAVIGATE CONTROLS - The Data Wheel scrolls through presets when HOME is lit or through editing rows when EDIT is lit. The left and right arrow buttons increment presets up and down respectively when HOME is lit or through edit **tabs** when EDIT is lit.

10. PRESET UP/DOWN - The UP ▲ arrow advances through presets and the DOWN ▼ arrow reverses. Holding either will accelerate in its direction.

Front Panel

11. SHORTCUT - Press to access the effect extension that is listed in the MAIN DISPLAY under SHORTCUT. This can include TEMPO, HARMONY HOLD and more.

12. μ MOD ON/OFF - Press to enable or disable modulation effects including chorus, flange, detune, tube resonance and more.

13. DELAY ON/OFF - Press to enable or disable timed echo, tempo-based echo, slapback effects and more. Hold to enter a temporary tap tempo setting mode then tap at the tempo of your song.

14. REVERB ON/OFF - Press to enable or disable reverberation effects such as Hall, Room, Plate and Ambience. Hold to access MIC GAIN setting.

15. STEP - When the COUNT legend in the MAIN DISPLAY shows a number greater than one, tapping this will advance to the next step in the chain. Holding STEP enters the STEP programming menu.

16. HARMONY ON/OFF - Tap to add or mute the Harmony voices created by your voice and VoiceLive

2. Hold this footswitch to enter a temporary key setting mode then tap the Preset Up/Down, Shortcut and Step footswitches to set a fixed key and scale. See Using A Fixed Key in VoiceLive 2 for the Lead Singer section for more detail on using fixed key to guide harmonies.

17. DOUBLE ON/OFF - Adds or mutes the Doubling voices assigned to the current preset. The Doubling voices are constrained to unison intervals only.

18. FX ON/OFF - Press to add the serial effects of Transducer (megaphones, distortion, hi-pass etc.) and /or Hard Tune including scale-based Pitch Correction. Each preset may be set to enable either or both effects. Holding the FX footswitch enters BYPASS + TUNER mode which mutes all effects except TONE and allows silent guitar tuning.

Back Panel



1. MIC and LINE inputs - Connect your microphone or line level audio device's output here. Only one should be connected at a time. Hold the REVERB footswitch to set gain when changing back and forth between MIC and LINE ins.

2. GUITAR IN and THRU - Connect a guitar to the GUITAR IN to guide harmony and mix the guitar signal into the main output. Connect the THRU to your guitar amp and remove the guitar from the main mix output.

3. AUX In - An audio signal received here can be mixed into the main output or used to control harmony.

4. HEADPHONE Out - The main output is mirrored here to drive headphones. Adjust the headphone and main output volume with the OUTPUT setting controlled by turning the MIX knobs.

5. OUTPUTS - The XLR and TRS (1/4") produce the same balanced audio output. Both can be used simultaneously if required. Mono/Stereo configuration is found in the I/O tab of the SETUP menu.

6. DIGITAL IN/OUT - The S/PDIF-formatted DIGITAL OUT is always active. Selecting this DIGITAL IN instead

of the USB digital input is done in the I/O tab of the SETUP menu.

7. PEDAL Input - A standard expression pedal can be connected here to control the level of the Harmony and Doubling voices. Calibration is done in the EXPRESSION tab of the SETUP menu.

8. MIDI Connectors - A computer or controller keyboard connected to the MIDI IN offers preset control, realtime parameter control, and guidance of the harmony voices. MIDI IN and OUT can also be used as an alternative to the USB connection for backup and restore operations.

9. USB I/O - USB is a standard computer connection allowing transfer of digital audio to and from VoiceLive 2 as well as for MIDI control and MIDI preset backup. Configuration of the digital audio and MIDI settings is done in the SETUP menu.

10. POWER In - Connect only the supplied adaptor or one with the exact specifications shown on the back of VoiceLive 2.

11. POWER Switch - Press to turn VoiceLive 2 on and off.

Quick Start

Overview:

This chapter will help you get set up in the typical live performance setting with a microphone. You will learn how to connect external devices and how to set the microphone gain properly. At the end you will be ready to move on to experimenting with the vocal effects in the First Impressions chapter.

In this section we cover:

1. Initial connections
2. Setting microphone gain

See the section on Basic Editing Concepts for more information on VoiceLive 2's tabbed, style-based edit menus.

Step 1: Pre-Flight Check

Assemble the gear you need to get started. For now, leave your VoiceLive 2 and PA system turned off.

1. Vocal microphone
2. PA system or headphones
3. Harmony control instrument. This can be a Guitar, MIDI keyboard, external audio source such as an MP3 player or none if you plan to enter Key and Scale with the footswitches.
4. You will need a selection of cables listed below depending on your harmony control instrument and monitoring.
 - o XLR cable for your microphone
 - o 1/4" cable from your guitar
 - o MIDI cable from your keyboard
 - o 1/8" mini from an MP3 player
 - o XLR or 1/4" cables to feed your PA system

Quick Start

Step 2: Inputs

First, connect the XLR cable from your microphone to the MIC input jack on VoiceLive 2.

Next, connect the instrument or device you will use to control harmony. **On power-up, VoiceLive 2 will automatically configure all harmony presets to recognize which instrument is connected.** Only one of the following should be connected for this Quick Start.

- o **Guitar.** Connect the 1/4" cable directly from your guitar (no pedals between the guitar and VoiceLive 2) to the input jack labelled GUITAR IN. If you want your guitar to go through pedals and an amp, connect another 1/4" cable from the GUITAR THRU to either your first effect pedal or your amplifier.
- o **MIDI keyboard.** Connect a MIDI cable to VoiceLive 2's MIDI IN from your keyboard's MIDI OUT. Set your keyboard's MIDI OUT channel to channel #1 if it is not already.
- o **MP3 player (AUX Input).** Connect the output of

an MP3 player or another music source to the AUX input using a stereo 1/8" connector.

If you do not connect an instrument to the GUITAR IN, MIDI IN or AUX input, most of the harmony presets in VoiceLive 2 will default to global Scale mode in the Key of A Major (for this, see the section entitled VoiceLive 2 for the Lead Singer)

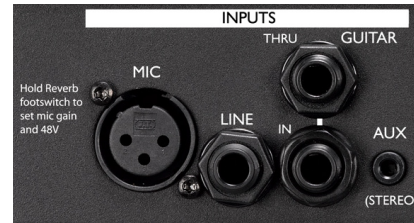

Quick Start

Step 3: Outputs

The typical setup for monitoring the output of VoiceLive 2 is to connect two 1/4" cables to a stereo channel in a PA mixer. VoiceLive 2 can be set to output in mono if preferred in the I/O tab of the SETUP menu.

If you are using a snake to connect to an offstage mixer, then the XLR outputs can be connected without the need for DI boxes. The output of the XLR jacks is the same as the 1/4" jacks: line level (maximum +16 dBu). Both the XLR and TRS output jacks can be used at the same time when required.

If you prefer to monitor with headphones, the output labelled with the headphones graphic will drive most headphone types that are equipped with an 1/8" jack.

Now you can connect the power adaptor and press the POWER switch to turn on the unit. NOTE: keep your PA level off until you set the mic gain level in Step 4.



Step 4: Set Mic Level

This step informs VoiceLive 2 how loud you plan to sing with your particular mic. We'll use VoiceLive 2's automatic MIC GAIN feature to quickly set the optimum level.

1. Press and hold the REVERB footswitch
2. If you need to activate phantom power for your condenser mic, adjust the onscreen PHANTOM parameter which will restart the level test
2. Sing for five seconds with peaks that are as loud as you plan to sing
3. Follow the prompts in the display to finalize mic level setting, cancel or redo the procedure

During performance, if you see the CLIP indicator light in the HOME screen, you can return to the automatic MIC GAIN feature to adjust the input level.

Step 5: Quick Start Settings

Ensure that the HOME and TONE buttons on the front panel are lit. Load preset #1 with the PRESET up or down footswitches. Ensure that the FX footswitch is not flashing. Tap it once if it is flashing to exit Bypass/Tuner mode.

Sing as you carefully raise your PA level or put on your headphones. You should now hear your voice clearly with Preset #1's effects added. If you would like to adjust the headphones level, turn the furthest right Mix/Edit knob to adjust the OUTPUT level.

Now you're ready for the next chapter: First Impressions. There you'll learn how to explore the presets in VoiceLive 2.

First Impressions

How To Audition Presets

The best way to sample VoiceLive 2's effects is to start with preset #1, sing, and then tap the PRESET up footswitch to audition the next preset. These factory presets contain collections of settings that affect your voice in different ways.

Holding PRESET up or down will automatically cycle in that direction. When working close to the unit, you can also use the DATA WHEEL to cycle through presets.

Finding Presets With The Wizard

Press the WIZARD button to search for presets by "Tags" which are preset attributes. Choosing a single tag will result in a broad search; adding successive tags (up to 3 total) will narrow your search. When you edit and store presets, you can assign tags yourself to assist in searching later.

The Wizard can also list the presets in alphabetical order when you change the Sort setting.

Using Harmony Presets

Most presets that have the HARMONY footswitch lit require that you play your guitar, keyboard or music source (AUX input) to arrange the harmony intervals musically around your voice. There are, however, presets where the HARMONY footswitch can be lit but that do not require musical input from you such as when the harmony intervals are unisons, octaves or fixed shifts used to create doubling and special effects.

If you want to audition presets without a music source, simply press the HARMONY footswitch to mute this effect each time you load a new preset.

You can read more about using harmony in the following sections:

- o VoiceLive 2 for the **Guitarist/Singer**
- o VoiceLive 2 for the **MIDI Keyboardist/Singer**
- o VoiceLive 2 for the **Lead Singer**

First Impressions

Using The Effect On/Off Switches

The Effect On/Off footswitches give you the option to modify the sound without changing to another preset. You can do so by tapping any of the 6 effects footswitches which include μ MOD (pronounced "micromod"), DELAY, REVERB, HARMONY, DOUBLE AND FX.

Tapping an effect that's off will add it to the effects mix and vice versa. All effects have default settings so you can merely press their associated footswitches to add them to your preset without editing. When you advance to the next preset, your on/off settings will be lost unless stored.



The SHORTCUT Footswitch

This footswitch extends the capabilities of the current preset. Depending on the preset, it could allow you to engage Harmony Hold, set the tempo for the Delay or turn on the Choir effect. The shortcut assignment for the current preset is clearly shown in the HOME screen.

Some shortcuts require holding the footswitch (e.g. Harmony Hold) and some require tapping it (e.g. Delay tempo). Every preset has a shortcut, so be sure to familiarize yourself with them all while exploring the product.



First Impressions

The STEP Footswitch

The Step feature allows you to create a series of up to 10 linked effect changes associated with a preset. In a preset that has steps, for example, tapping STEP could toggle to another preset's effects, turn on all of the effects at once, increase the Delay level by 6 dB or all of the above.

Some factory presets have been programmed with examples of steps. You can see that a preset has steps when the COUNT (graphic) item in the HOME screen is a number greater than 1. When you see this, you can press the STEP footswitch to cycle through the pre-programmed effect changes.

The STEP footswitch cycles forward through any steps present. The PRESET (down arrow) cycles backwards towards step 1 after which it will cycle backwards through presets again. When the Step count is 2, the STEP footswitch can be used toggle between the two settings.

Programming Your Own Steps

1. Select a preset as the starting effect in your chain.
2. Hold STEP for a moment to enter Step programming mode. Segments of the main display will change color.
3. To insert another preset's effect as the next step, use the PRESET footswitches to locate the desired preset.
4. If you want to change which effect blocks are on press the desired effect footswitches.
5. If you want to make an edit, press the EDIT button and make your changes. Edits made in Step insert mode before accepting are stored automatically to the new step.
6. Tap STEP to accept your new step and exit Step programming mode. The COUNT legend in the main display will increment by one and the STEP footswitch will light.

To cancel and exit Step programming mode, hold STEP.

First Impressions

To delete any single step, locate the step you want to remove then enter Step programming mode. Tap SHORTCUT to delete the current step.

To speed Step programming, all insertions and deletions are automatically stored when you exit Step mode. If you want to experiment without affecting an important Step chain, you can either store the preset to another location first (Steps are stored with presets) and work there or perform a backup before experimenting and restore when done.

The Tone, Pitch and Guitar FX Buttons

These three buttons apply live engineer features that are “global” in that they affect all presets.

The TONE button makes your voice sound smoother and brighter by applying studio-grade adaptive compression, EQ, de-ess and gating. We recommend that the TONE button be turned on and left active to improve your overall vocal tone.

Press the PITCH button to add subtle Auto Chromatic pitch correction which helps you sing more in tune.

If you have a guitar connected to the GUITAR IN jack, pressing the GUITAR FX button will apply effects to your guitar sound that will be heard through VoiceLive 2’s main outputs. The guitar effects and dry signal will be muted if a jack is connected to the GUITAR THRU jack.

Press and hold any of these buttons to access their menus and make global changes.



First Impressions

Activating BYPASS + TUNER Mode

Press and hold the FX footswitch to remove all effects from your voice except TONE (when active). The Tone feature remains active in BYPASS + TUNER (Bypass) so your voice does not sound darker when switching to Bypass for speaking or singing with no effects.

If you have a guitar connected to the GUITAR IN, its output will be muted in Bypass and the Tuner display will become active so you can tune silently.

Tap the FX or any other footswitch to exit Bypass mode and return to the previous display screen.

Changing The Mix

The effects balance in VoiceLive 2 is adjusted at the factory to suit many situations. The Mix/Edit knobs change the levels of :

- o the combined Harmony and Doubling voices,
- o the combined Delay and Reverb effects

- o your guitar and its Guitar FX (as long as GUITAR THRU jack is unused)
- o the overall output level

NOTE: These adjustments are “global” meaning they affect all presets by the same amount.

With the HOME button lit, turn any of the 4 MIX knobs. This will present the MIX screen where you can see and adjust these levels. After approximately 3 seconds the display will revert back to the HOME screen. Your new balance will remain in effect each time you power up the unit until they are changed again.

If you want to adjust the level of a music source connected to the AUX IN, you can do so with the AUX LEVEL setting in the SETUP menu under the I/O tab.



Basic Editing Concepts

When you want to go beyond turning effects on and off to make changes in your preset, press the Edit button to explore Voicelive 2's editing tabs. Each of the effect footswitches has a related tab you can access with the NAVIGATE left and right arrow buttons. Holding the left or right NAVIGATE buttons will jump between the uMOD and PRESET tabs.

If you make changes you want to keep, presets can be edited and stored in place or to another location. Individual factory presets can be restored at any time from the STORE menu.

Once in the Edit screens, you can cycle up and down to browse the rows of parameters by turning the DATA WHEEL. The settings are arranged left to right so that they can be accessed by the Mix/Edit knob immediately below each parameter. Turn the knobs to make changes.

The first row of each tab contains the Style for that effect. Styles speed editing by collecting a group of parameter values together. If you like the sound of a

particular preset but you want a shorter reverb, for example, changing the Reverb style is the quickest way to accomplish this.

You can also vary the level of each effect in the edit tabs. All effect blocks except for FX (Transducer and Hard Correct are always 100% wet) and Rhythmic can be adjusted.

To store your edits press the STORE button. This will show the preset naming and destination preset number display. Press STORE again to save. If you want to cancel, press the HOME button and then load any other preset.

To store from a standing position, hold PRESET down arrow and STEP together. The LCD will show "STORING" briefly and your edit is stored.

VoiceLive 2 for the Guitarist/Singer

Overview

Guitarists have bonus features in VoiceLive 2. In addition to sensing the guitar chords to guide harmony, VoiceLive 2 offers the guitarist:

- o Effects, including compression, EQ, modulation and reverb dedicated to the guitar
- o Guitar mix to main outputs
- o Chromatic Tuner

By this section we assume you have completed the Quick Start and have your voice set to a comfortable level in your PA or headphones.

Acoustic Guitar

If you haven't by now, connect a cable from your pickup-equipped acoustic guitar to the GUITAR IN as described in the Quick Start. You should now hear your guitar sound mixed with your voice.

To adjust the balance of guitar and voice, ensure the HOME button is lit then turn the third Mix/Edit knob. This will present the MIX screen so you can adjust the

level of your guitar.

Press the GUITAR FX button if it is not already lit. This will add the default effects to your guitar. The Guitar FX on/off status and style is static through preset changes.

Now you can sample the harmony-based presets with harmonies closely related to your guitar playing. You should now hear nicely produced lead vocal, harmony vocals and guitar from your PA system or headphones.

Electric Guitar

Connect a cable from your electric guitar to the GUITAR IN. Connect another cable from the GUITAR THRU to your first guitar effects pedal or to your amp. Set your guitar amp volume to a level compatible with your vocals.

By connecting a jack to the GUITAR THRU, the guitar signal is removed from the internal mixer and effects paths in VoiceLive 2.

If you hear a buzz from either your guitar amplifier or

VoiceLive 2 for the Guitarist/Singer

the PA VoiceLive 2 is connected to, press the GND LIFT (ground lift) button to silence it.

Now you can sample the harmony-based presets with the harmonies musically related to your guitar playing.

Tuning Your Guitar

The Bypass + Tuner function works for both acoustic and electric guitars. The tuner is a chromatic type so you can use alternate tunings as well as standard tuning.

To activate the tuner, hold the FX button. This will:

- o Change the main display to show the tuning meter
- o Mute the guitar in both the OUTPUTs and THRU
- o Remove all effects on the voice except TONE.

Tap the FX footswitch to exit Bypass + Tuner mode.

Guitar Performance Tips

To ensure that the harmony voices follow your guitar closely, it's best to play cleanly with chords containing at least two notes. If you want to sing right at the start

of a song, it's important to briefly play a chord first. A recognized chord will show "NP" in the LCD display.

Your guitar should be well-tuned to the onboard tuner.

If the song section you want vocal harmony on has fast chord changes, single note runs or very slow arpeggios, you can use presets based on a fixed Key to produce harmony. To find out more about this see Using A Fixed Key (aka "Scale") section in the chapter entitled VoiceLive 2 for the Lead Singer.

Setting Fixed Key and Scale With Guitar

If you wish to try using this type of harmony it's easy. Find a preset with the SHORTCUT set to SET KEY. Tap the SHORTCUT button when the root of the chord you're playing is the Key you want. You can change the Scale type with the STEP footswitch if you like. To accept this Key and Scale, just keep playing - the menu will time out automatically. If the preset SHORTCUT is not assigned to SET KEY, you can hold the HARMONY footswitch in any preset to enter the same menu.

VoiceLive 2 for the MIDI Keyboardist/Singer

Overview

Using MIDI opens up a wide range of harmony and parameter control options. This section will discuss the basics of setting MIDI channel and performing with a MIDI keyboard/synth to control harmony.

By this section we assume you have completed the Quick Start and have your voice set to a comfortable level in your PA or headphones.

MIDI Hookup and Channel Selection

If you haven't already, connect a MIDI cable between your keyboard's MIDI out and VoiceLive 2's MIDI IN. Play a note on your keyboard and check VoiceLive 2's display to see if the MIDI indicator lights. If it doesn't, set the MIDI transmit channel of your keyboard to 1 (VoiceLive 2's default) or perform the following quick MIDI receive channel procedure.

Hold the PRESET up and SHORTCUT footswitches briefly to enter MIDI Setup. Press any note on your keyboard. This will automatically configure VoiceLive 2's

MIDI receive channel to match your keyboard's. Tap the SHORTCUT footswitch to exit. You should now see the word MIDI flash in the main display when you play your keyboard. You can also set MIDI channel manually in the MIDI tab of the SETUP menu.

MIDI IN and USB

To use the MIDI IN while you have a USB cable connected, press the SETUP button, locate the SYSTEM tab and turn the USB CONTROL setting to OFF. This will enable the MIDI IN. Alternatively, you may also remove the USB cable to access MIDI IN.

When you want to restore computer control of VoiceLive 2 over USB, or you want to access the VoiceSupport application's features, you can turn the USB CONTROL parameter back to On.

MIDI Controlled Harmony

Now that you've followed the preceding section, you can sample the many presets that feature the harmony effect. Load a preset with the HARMONY footswitch

VoiceLive 2 for the MIDI Keyboardist/Singer

lit or tap it to engage harmony in any preset. Now you can play a song on your keyboard while singing and hear how the harmony voices adjust musically as you play the different chords in your song. As each chord is recognized, the LCD display will briefly show “NP” meaning NaturalPlay.

The factory presets that have the word “Notes” in their names use another form of harmony control called “MIDI Notes”. These presets allow you to tie the pitch of the harmony voices to the exact notes you play. The maximum number of notes can be 4 or 8 depending on whether Harmony Doubling is activated in the HARMONY tab of the EDIT menu.

MIDI Performance Tips

In chords without a clear third, VoiceLive 2 will assume a major chord, so when you play in a minor key, and as a general rule, you should always include a third when changing chords.

If you want to sing right at the beginning of your song, it's important to play a chord just before you sing

If you sing while playing a chord and then press the sustain pedal, you're able to add a keyboard embellishment that doesn't affect the harmony.

By default, program change messages from your keyboard are ignored so you can change your keyboard sound without changing VoiceLive 2's preset.

Your mod wheel can be used to add or remove vibrato in harmony presets.

Alternate Harmony Method

For some songs, fixed scale harmony (not controlled by an instrument) works well. To find out more about this see Using A Fixed Key (aka “Scale”) section in the chapter entitled VoiceLive 2 for the Lead Singer.

VoiceLive 2 for the Lead Singer

Overview

This section is for those who do not play an instrument such as a MIDI keyboard or guitar. You are still able to experience VoiceLive 2's vocal harmony effects with these methods:

- o Using fixed Key and Scale
- o Singing to music-only playback
- o "Borrowing" from another player's instrument

By this section we assume you have completed the Quick Start and have your voice set to a comfortable level in your PA or headphones.

Using A Fixed Key (aka "Scale")

This is the main method for creating harmony used successfully in the original VoiceLive processor. Briefly, all of the chords in an entire song and your melody can belong to a single "Key". You can input this key in any harmony preset by holding the HARMONY footswitch or using the SET KEY shortcut if it's assigned in the current harmony preset.

When the match of Key and song is correct, a fixed Key is nearly indistinguishable from recorded harmony. There are limitations however:

- o Fixed Key works for many, but not all songs.
- o Fixed Key works best with 3rd harmony intervals; adding the 5th (interval: Higher) reduces the number of compatible songs.

You should be singing with musical backing and stay true to a A=440Hz reference. This could be a CD or other musicians. Choose a simple song to start with. Determine the Key of your song; this is often the first or

VoiceLive 2 for the Lead Singer

last chord in a song without extensions. For example G Major is a valid Key, Gm7b5 is not.

Hold the HARMONY footswitch to enter Key Set mode then use the PRESET up and down footswitches to enter the Key. The STEP footswitch will cycle through the 3 Major and 3 Minor alternate scales that can be chosen if your harmony intervals sound incorrect at certain chord/melody combinations.

Note that the Key you set is global so you can try other presets with your song without entering Key again.

If you're lucky the first time, you'll be rewarded with soaring harmony over your whole chorus or song. If not, you can try the following:

- o Try a different Key, perhaps a 5th away from your first choice.
- o Choose a different Major or Minor alternate Scale.
- o Choose a preset with only the 3rd (High) interval.
- o Create a Step to change Key at the right moments.
- o Move on to the next options listed.

Singing To Music Playback

VoiceLive 2 can derive musical information from fully mixed music tracks. For this alternative you'll need:

- o Music source device. This could be an MP3 player, computer, CD player etc.
- o Recorded music without vocals. This could be your latest CD tracks minus your vocals or Karaoke tracks available on the web

Connect as described for MP3 Player (AUX input) in the Quick Start section. When you power up VoiceLive 2, it will auto-recognize the AUX input as the harmony music source. Choose a harmony preset and play your music source. You should hear your music, voice and the harmonies in your PA system or headphones.

Use the volume control on your music source device to adjust the balance of music to vocals. You can also adjust the AUX level in the SETUP menu, in the I/O tab.

VoiceLive 2 for the Lead Singer

“Borrowing” From Another Player

If you play with a guitarist or MIDI keyboard player, you can use their playing to guide the harmony voices in your VoiceLive 2.

Your guitarist can connect to the GUITAR IN and THRU then to their pedalboard or amp. Their guitar sound will remain the same and you can turn the harmonies on and off when you need them. The only limitation is the length of cable because high impedance signals lose signal over long cable runs. If this is an issue, you could use a preamp out or effects loop output from the amp.

Alternatively, you can run a MIDI cable from your keyboardist's controller to your VoiceLive 2. This has no effect on the keyboard sound and cable runs are not a problem.

With either solution, you can co-ordinate with the player to make sure they are playing complete chords where you plan to use harmony.

Monitor Placement

Try to ensure that your keyboard amp or monitor is not facing directly into your mic as this can confuse VoiceLive 2's pitch detection and result in poor sounding harmony voices as well as bring on feedback.

Foot Control

When changing presets or toggling effects with the footswitches, be sure to tap and not hold them. Many of the footswitches have alternate functions that are accessed by holding which could cause confusion in your performance.

Harmony Contrast

Your performance will be more interesting to your audience when you use Harmony and Doubling to highlight song sections as opposed to using them throughout a whole song or set of songs.

Singing Tips For Harmony

The more in-tune you sing, the better the harmonies will sound. Most harmony presets have a slight amount of pitch correction (known as Smoothing) on the harmonies but your pitch is still very important.

Connecting VoiceLive 2 To A Computer

The USB Connection

Connecting the supplied USB cable between VoiceLive 2 and your Mac or PC computer offers the following benefits:

- o Audio input and output for recording, processing and monitoring without a separate audio I/O box
- o MIDI connection from your computer to VoiceLive 2 without an external MIDI interface.
- o Easy backup and restore of preset and system settings
- o Simplified system updates
- o Information and tutorial videos

The VoiceSupport Application

This is a web-enabled application intended to enhance your experience with VoiceLive 2. As well as keeping you up-to-date with the latest TC-Helicon news items and support materials, VoiceSupport simplifies system updates, preset backups and product registration.

VoiceLive 2 does not need to be USB-connected in order to access the tutorials, news and other downloads. Also, you may view videos and other media from the included CD without connecting to the internet.

PC Installation

1. Place the supplied VoiceSupport application CD in your computer CD drive. If the install wizard does not start automatically double click the setup.exe file on the CD.
2. Follow the instructions on the installation wizard.
3. Connect VoiceLive 2 when prompted.

VoiceSupport will run automatically when the install is complete.

Mac Installation

1. Place the supplied VoiceSupport application CD in your computer CD drive.
2. Open the VoiceSupport.pkg icon on the CD to start the installation.
3. Follow the prompts on the installation wizard.

Connecting VoiceLive 2 To A Computer

After the wizard finishes, connect your VoiceLive 2 and start VoiceSupport, located in the Applications folder.

The first time you open VoiceSupport it may take a while to load as it must download all of the newest content.

When the application finishes loading it should display “VoiceLive 2” in the top right corner and a connection icon, indicating that connected was successful. If it says “Not Connected”, check that the USB cable is properly attached and then click the blue connection button. Check the FAQs and Troubleshooting section if this is unsuccessful. Also, VoiceSupport is updated periodically so check that your version number (shown on VoiceSupport’s HOME page) is current with the version shown on the TC-Helicon website. If a newer version is available, you can download it from our website.

VoiceLive 2 And Digital Audio

Here are a few common methods of using VoiceLive 2 with a USB-connected computer and an audio

application (DAW):

1. Capturing a full mix of your performance
2. Processing vocals from your DAW
3. Recording dry vocal and guitar tracks

We assume you are familiar with configuring your audio application for input and output and that you understand connection of VoiceLive 2’s inputs and outputs.

Method 1 - Capturing a full mix of your performance:

Set VoiceLive 2’s I/O parameters as such:

DIGITAL IN: USB: STEREO

DIGITAL OUT: FULL MIX

Connect your mic and headphones to VoiceLive2 and pick a preset you like. VoiceLive 2 will send the fully processed sound to your DAW and you’ll be able to monitor through your headphones or the analog audio outputs of VoiceLive 2. In order to set VoiceLive 2’s sample rate, play a little bit of audio from your DAW

Connecting VoiceLive 2 To A Computer

before recording your vocal track.

Method #2 - Processing vocals from your DAW:

To use VoiceLive 2 as an effects insert, set the I/O parameters as such:

1. DIGITAL IN: USB: VOX L / INST R
2. DIGITAL OUT: FULL MIX

Configure an aux send in your DAW to send the vocal track to VoiceLive 2's left input and the instrument track to the right. You can monitor through VoiceLive's headphone or main outputs. When playing back using VoiceLive 2 as the output audio device, don't forget to set the DIGITAL IN back to USB: STEREO.

Method #3 - Recording dry vocal and guitar tracks:

You'll need a fully dry mono vocal track and optionally, a dry instrument track (guitar or keyboard) or midi performance if you plan to use harmony. Set the I/O parameters as such:

1. DIGITAL IN: USB: FULL MIX

2. DIGITAL OUT: VOCAL & GUITAR

Connect your mic and a guitar to VoiceLive 2 and your headphones to the headphone out. Even though you'll hear fully processed vocals and guitar (with Guitar FX) in the headphones, the output feeding your DAW will be separate dry vocal and guitar that you can process later with Method #2.

Digital Input Notes:

Sample rate is synchronized automatically to the incoming digital audio stream. There is no independent configuration of sample rate in VoiceLive 2. When processing an analog input such as the MIC and sending to VoiceLive 2's digital out, sending a short bit of audio from your recording application to either Digital in will set the sample rate.

When DIGITAL IN is set to USB:- or SPDIF: VOX L / INST R, the MIC and GUITAR IN are disabled.

When DIGITAL IN is set to USB (or SPDIF): STEREO, harmonies will follow the stereo audio coming from the selected digital input on presets where NATURALPLAY

Connecting VoiceLive 2 To A Computer

is set to AUX INPUT.

Digital Output Notes:

USB audio output will not function when either of the SPDIF: options is chosen for the DIGITAL IN parameter.

SPDIF digital output is always available regardless of DIGITAL IN or OUT settings.

USB Audio And ASIO Applications

PC-based ASIO apps such as Cubase may require you to install a WDM to ASIO “wrapper” such as ASIO4ALL which is available at www.asio4all.com in order for VoiceLive 2 to be recognized as an audio device.

Selecting The Audio Device

In the Mac and Windows operating systems, you can select VoiceLive 2's audio device in your workstation program by name. In some Windows XP DAW apps, however, the name of the audio device may be “USB Audio Device”.

USB And MIDI Control

To use VoiceLive 2's MIDI IN jack for harmony, preset change or realtime control **while USB is connected**, enter the I/O tab in the SETUP menu and set USB CONTROL to OFF. USB audio will function normally but MIDI will only be accepted by VoiceLive 2's through its MIDI IN port.

To re-enable VoiceSupport's features and reception of MIDI from your DAW, turn USB CONTROL to ON.

In this part of the manual we shed light on the individual editing parameters in VoiceLive 2.

This section discusses:

The Global controls: Tone, Pitch and Guitar FX

The Edit menu including all effect-specific tabs

The Setup menu and its 4 tabs

The Global Controls: Tone

The Tone Button

The Tone button activates what we call the “Live Engineer Effects”. These are different from standard vocal processing effects in that they adjust their settings to your particular voice and the way you sing at different times of your performance just like a professional audio engineer will. All EQ and compression enhancements applied here will affect the overall sound of VoiceLive 2 including Harmony, Doubling, Reverb etc.

The suite of effects that make up Tone are:

- o Adaptive Shape EQ
- o Adaptive Compression
- o De-Ess
- o Adaptive Gate

The TONE Tab

Press and hold the Tone button to enter this screen and make adjustments or view settings. This will present the TONE tab allowing convenient control of these four

processors in one screen. At any time you can exit the tab menus by pressing the Home button.

The factory settings for the Tone button are:

- o SHAPE
ADAPTIVE=X(On), SHAPE=50%
- o COMPRESS
ADAPTIVE=X(On), COMPRESS=50%
- o DE-ESS
DE-ESS=50%
- o GATE
ADAPTIVE

These settings are intended to apply to a broad range of singers' tastes and PA equipment. Making adjustments consists of turning the Mix/Edit knobs below the LCD and listening to the results. You can also cycle the Tone button on and off while editing to hear the difference between your effected and non-effected voice.

Note that there is a slight lag between adjusting the

The Global Controls: Tone

Adaptive effects and hearing the effect as the algorithm re-assesses your voice input.

The ADAPTIVE Check Boxes

These show whether the automatically-adjusting Adaptive feature is enabled for the SHAPE or COMPRESS controls.

NOTE: If either or both ADAPTIVE check boxes is unchecked, the associated control is set to MANUAL. Manual adjustment is possible by using the Navigate buttons to go to the edit tab associated with it and changing the controls on that tab.

The SHAPE Control

“Shape” is the name given to the automatically adjusting EQ that is activated by the ADAPTIVE check box. When the Adaptive feature is activated, Shape processing offers an EQ curve that adds an airy brightness, or “sizzle” to your voice while reducing “mud” due to the proximity effect from singing closely into a cardioid microphone. Adjusting the control from 0% to 50% reduces mud

while increasing brightness to a useful range for your voice. Turning from 50% up to 100% adds more brightness.

Reducing Mud

For singers who have a voice with less bass frequencies, the “mud” reduction may be less and perhaps not noticeable at all. This is a good thing - your voice is nicely balanced regarding bass frequencies. For the average male singer or women who sing closely on their mic, the reduction in bass will be noticeable and beneficial. When voices have too much bass, they tend to become lost in the other instruments that occupy those frequencies resulting in sonic clutter. Reducing bass has the natural effect of emphasizing mid and upper frequencies which allow the voice to cut through dense instrumentation.

Lastly, the term “proximity effect” and “cardioid” need to be clarified as they can cause bass build up. The typical microphone used by singers has a pickup pattern called “cardioid” or heart-like, because it picks up less sound at the rear than at the front. This intends to reduce other instruments or sounds from getting into the front of the

The Global Controls: Tone

mic. A side effect of this that singing closely on a cardioid mic adds more bass frequencies than your voice actually has. This is called “proximity effect” because it is caused by closeness to the mic. The adaptive Shape feature of VoiceLive 2 listens continually to your voice through your mic and adjusts to make your voice sound like it is professionally produced and balanced.

Adding Highs

The other facet of the Shape feature is that it adds high frequencies, also known as “air” or “presence” without making your voice sound “tinny”. The vocal sounds we hear on CDs and the radio are not typically what you hear when you listen to a singer acoustically. Commercial vocal sounds are more of a hyper-reality designed to flatter the voice or voices and make them cut through a group of instruments and thus make a larger impression on the listener. The Shape feature, used at moderate settings, emulates this sound through the average microphone and PA system.

When making Shape adjustments, it's important to sing while listening to the PA system your audience will hear

rather than only judging by your monitor sound.

The COMPRESS Control

With the ADAPTIVE control activated, the COMPRESS control reduces the amount of range between louder and softer singing to produce more even-sounding vocals. It does so by listening to your singing over time (less than 30 seconds) and adjusting accordingly.

Typical compressors require multiple controls, knowledge and experience, and time spent testing and refining over a performance. With TC-Helicon's Adaptive Compress feature, these are not required.

The factory setting of 50% strikes a good balance between moderating dynamics in your singing without incurring feedback, a side effect of compression used in a live mic setting. If you have a high quality monitoring/PA setup with a flat frequency response and you want more compression, by all means add more with the COMPRESS control. Be aware though, that average quality systems have frequency peaks that may cause feedback with lots of compression combined with

The Global Controls: Tone

Adaptive Shape EQ.

- o Note that, in order for the Adaptive Compression feature to work properly, you must have your mic gain set properly either with by using auto MIC GAIN or by setting it manually.

Compression: A Primer

You may not notice this effect as easily as with Shape. It can be quite subtle until you educate your ears to compression. Following is a very brief description.

We typically sing dynamically, like this (capitals are used to show louder dynamics):

“I **LOVE** to watch you **WALK** down the **STREET**”

At acoustic singing levels with no, or very quiet instrumentation, this would sound fine. When amplified however, the loud words become strident and even worse, quiet words can be lost in the instrument sounds. The louder the PA and band the more pronounced the loud parts become. Compression seeks to do the following to your dynamics:

“I LOVE to watch you WALK down the STREET”

Applied appropriately, the difference between loud and soft is reduced without killing the interesting dynamics in your performance.

The DE-ESS Control

There is a side effect that comes from adding high frequencies and compression to your voice, and that's excessive sibilance. Sibilance can be described as the brief whistle that accompanies “S”, “T” and “D” syllables in your vocal performance. Again, when singing acoustically, there is no issue with these sounds. It's when you amplify and combine with boosted highs and compression that they can become piercing.

Voicelive 2's DE-ESS control monitors the level of sibilance and, when it is detected, will quickly and transparently reduce it. Typically, it's only briefly required and it then gets out of the way allowing the silky brightness to remain on the voiced portion of your singing.

The Global Controls: Tone

There is only the single DE-ESS control; no other manual adjustment settings are required. The factory setting of 50% gently reduces sibilance without becoming obvious. Higher settings of compression and Shape or a bright, sibilant voice may require a higher setting.

The GATE Control

When set to the factory default of ADAPTIVE, the GATE control on the Tone Edit screen helps in two very important ways by:

1. Minimizing feedback
2. Reducing the amount of audible effects processing on sounds entering the mic other than your voice.

A typical, fixed gate works by shutting off, or reducing the level of any signal below a threshold that you set. When you sing louder than that threshold, the gate will open and your vocal will come through the PA. When you aren't singing, the gate will close and block sounds around you.

The Adaptive Gate in VoiceLive 2 works automatically with your singing style to provide the optimum balance between how loud you have to sing to open the gate and how much other noises are reduced.

For troublesome audio environments, or for those who are familiar with setting manual gate parameters, there is also a MANUAL setting on this page. Further controls for the Gate are on the GATE Tab discussed on pg. 46.

The EQ Tab

From the TONE tab, you can access the EQ tab by pressing the right Navigate button. The EQ tab will be highlighted and you will see either the ADAPTIVE, SHAPE, and WARMTH controls when ADAPTIVE is On or parametric EQ controls when ADAPTIVE is Off.

EQ Tab With ADAPTIVE On

When the ADAPTIVE control is set to ON (the factory default), most of the adjustment is done automatically so fewer controls are required. These are:

ADAPTIVE ON/OFF

The Global Controls: Tone

SHAPE AMOUNT

WARMTH ON/OFF

ADAPTIVE ON/OFF

This activates the automatic EQ algorithm and changes the control set for the EQ tab. When set to ON, this places an X in the ADAPTIVE check box in the TONE tab and allows editing of the SHAPE control in that tab. When set to OFF, this presents the manual parametric EQ controls, and removes the check in the ADAPTIVE box on the TONE tab.

SHAPE AMOUNT

This is a duplicate of the SHAPE control found on the TONE tab discussed previously.

WARMTH ON/OFF

This control returns a narrow band of low frequencies for singers who prefer this sound. The majority of the “mud” frequencies are still reduced automatically when using this control.

EQ Tab With ADAPTIVE Off

Turning ADAPTIVE off presents manual parametric EQ controls for users who understand this type of equalization. There are 3 bands of control:

Low band shelving

All band fully parametric peak/dip control

High band shelving

The 2 “Shelving” EQs boost or cut all frequencies below or above the the frequencies set by the LOW FREQ and HIGH FREQ controls respectively. These are most like the common Bass and Treble controls on a stereo system.

The “Parametric” EQ boosts or cuts the frequencies within a selected band that is defined by a center frequency (PARA FREQ) and a width control (PARA WIDTH). For vocals, the gain of a narrow parametric band is typically reduced to overcome room or voice resonances and smooth the sound although experienced users may boost a band felt to be missing in a particular

The Global Controls: Tone

voice as well.

The 3 GAIN controls allow +/- 12 dB of adjustment. The 3 FREQ controls range from 20 Hz to 20 kHz.

LOW GAIN

Boosts or cuts the range of frequencies **below** the frequency set by the LOW FREQ control.

LOW FREQ

Allows you to define the frequency range for the low shelf by choosing the highest frequency below which boosting or cutting is possible.

HIGH GAIN

Boosts or cuts the range of frequencies **above** the frequency set by the LOW FREQ control.

HIGH FREQ

Defines the frequency range for the high shelf with the selection of the lowest frequency above which boosting or cutting is possible.

PARA GAIN

Boosts or cuts the band of frequencies centered at the setting of the PARA FREQ control and its associated WIDTH.

PARA FREQ

Defines the center of the parametric band.

PARA WIDTH

Defines how narrow or wide the parametric band is to be. The ends of the control range are labelled "NARROW" and "WIDE" to add meaning to the numbers in the middle of the control range.

The COMPRESS Tab

The controls on this tab change depending on the status of the ADAPTIVE setting in the same way as the EQ tab. Compression concepts are discussed earlier.

COMPRESS Tab With ADAPTIVE ON

The ADAPTIVE Compression algorithm performs automatic processing which reduces the amount of

The Global Controls: Tone

adjustable parameters. As such, once ADAPTIVE is enabled, the only control is COMPRESS.

COMPRESS

This allows you to vary the amount of peak reduction by the ADAPTIVE compression algorithm. The factory value is 50% but you can increase or decrease as you require.

COMPRESS Tab With ADAPTIVE OFF

Turning off ADAPTIVE compression switches compression to manual control. Be sure to reduce the level of your PA or switch to headphones when adjusting the manual compressor because high settings can cause more gain and thus feedback.

THRESHOLD

This sets the singing level at and above which the amount of gain reduction (compression) specified by the RATIO control will occur. The range is 0 dB to -30 dB: 0 dB being the loudest input signal VoiceLive 2 can accept without distortion and -30 dB being a very quiet signal. If you sing consistently more quietly than the

THRESHOLD, you will not hear any compression. You can see your input level on the IN meter on the Home screen. A good setting for experimentation is -10 dB.

RATIO

This sets how much gain reduction you prefer when your voice level goes above the threshold. The range is from 1:1 (no gain reduction) to 4:1 (maximum vocal gain reduction). The default setting for RATIO is 4:1.

The number on the left side of the : (colon) symbol is how loud the peaks in your singing have to be in order to achieve a 1 dB gain increase. A brief example of how adjusting the ratio of compressor works is this: say a word you sang went 4 dB over the threshold when the Ratio was set to 4:1. The compressor would only allow it to go 1 dB louder.

Note that the RATIO control has to be set above 1.0 (1.0:1) to apply any compression regardless of the setting of the THRESHOLD.

The Global Controls: Tone

Also note that automatic makeup gain occurs depending on your combination of THRESHOLD and RATIO. A side effect of compression is that it can reduce apparent level until makeup gain is applied to raise the overall level.

The GATE Tab

If your musical accompaniment is loud or you hear feedback, the GATE tab will enable you to make adjustments.

GATE

This sets the Gate type. The factory default is ADAPTIVE, which performs automatic level assessment for the average musical setting. You can also turn the gate to OFF with good results if you are in a quiet, low volume musical environment. This can be set to MANUAL if you have more challenging requirements. When the GATE is set to MANUAL, an additional parameter, THRESHOLD, is displayed.

LEAD ATTEN

This controls how much your lead voice level is reduced

(attenuated) when your voice falls below the Gate threshold and the Gate closes. This setting applies whether the GATE is set to ADAPTIVE or MANUAL. The factory default setting of -3 dB (a reduction of 3 dB) is gentle enough that if your voice strays below the threshold, it is not cut off completely. If you are in a feedback-prone environment (loud monitors plus Shape and Compress on) you can increase this to reduce more. A setting of 0 dB offers no gain reduction on your lead voice at all. Settings of -30 to OFF effectively mute your voice when the Gate is on.

HARM ATTEN

This sets the amount of attenuation for the Harmony and Doubling voices when the Gate closes. They have a separate attenuation setting to reduce chatter caused by instrument sounds entering the mic and being harmonized when you aren't singing. The factory default attenuation amount of -10 dB should work well in many situations, but you can further reduce the level if you still hear harmonized instrumental chattering when you stop singing.

THRESHOLD (MANUAL Gate Only)

This parameter becomes visible when the GATE has been switched to MANUAL. The THRESHOLD defines the minimum singing level you need to reach in order for the Gate to open and let your voice sound. The factory default setting of -40 dB is very sensitive to allow a wide range of singing levels but it may also allow more nearby instrumental sounds through when you are not singing. In this case, further adjustment from -39 dB and upward may be needed.

The Global Controls: Pitch

The Pitch Button

Pressing the Pitch button activates auto chromatic pitch correction. For most applications, this is all that is required to set this feature. There is no need to set Key or Scale; all notes that you sing in the 12 tone western chromatic scale are corrected to the nearest scale tone.

This type of vocal pitch correction is quite subtle at its factory setting of 50% but even the most highly skilled and on-pitch singers will hear a slight chorusing from the PA or monitors with it engaged.

Press and hold the Pitch button to access the PITCH tab and adjust the single parameter for this feature. Once you see this tab, the Pitch button can be cycled on and off to allow you to hear the difference. Press the Home button to exit the Pitch edit tab.

AUTO-CHROMATIC AMOUNT

The factory default value of 50% is active when you enter the PITCH edit tab. Turning the control towards 0% reduces the correction effect and turning towards 100% increases. Above 50% the effect becomes more

noticeable when you slide from note to note. This is the effect of faster transition speed between your input note and the closest scale tone as well as the fact that the algorithm is trying to pull you closer to the target.

For those singers who want to use or experiment with scale-based pitch correction and perhaps even the jagged, modern HardTune effects, there are presets set up specifically for this that can be found by pressing the Wizard button and choosing CORRECT or HARDTUNE as the Tag.

The Global Controls: Guitar FX

The Guitar FX Button

For those guitar players who mix their guitar through VoiceLive 2's outputs by not connecting to an external mixer or amp via the GUITAR THRU jack, the effect processors enabled with the Guitar FX button yield added sonic depth and clarity.

Pressing the Guitar FX button will apply default settings for the Reverb, μ Mod, EQ and Compress processors to your guitar. Press and hold the Guitar FX button to see the edit tabs for these processors. Any time these menus are displayed, you can cycle the GUITAR FX button to compare your effect edits with dry guitar sound.

The Guitar FX do not change with VoiceLive 2 preset selection. The choices you make for effect styles should be useful across all of your repertoire. You can, however, use MIDI CC messages from a MIDI sequencer or MIDI pedalboard to make changes during your performance. See the MIDI Implementation chart for the CC numbers.

GUITAR Tab

This tab allows you to control the guitar mix level and the style and mix settings for the Reverb and μ Mod effects.

GUITAR

This is the same Guitar mix control as the one that is activated when you access the main Mix screen. You can adjust the level of the guitar in VoiceLive 2's overall mix in either menu. The range of this control is -30 dB to +24 dB in order to adapt to a wide range of guitar output levels.

Note that this does not effect guitar level when a jack is connected to the GUITAR THRU connector and the guitar signal is passed on to an external amplifier.

GUITAR PHASE

Phase reverse can help to minimize low and low-mid frequency feedback on acoustic guitars with loud monitoring. The effectiveness of phase reversal depends on your guitar's physical location in relation to the monitor. If you move around the stage, reversal may not help, but if you typically remain in the same position it

The Global Controls: Guitar FX

can help considerably.

To see if phase reversal will help, stand where you will perform in relation to your monitor and carefully turn up the level of your guitar with your guitar's onboard volume control until it starts to feed back. Note the volume if the control has an indication then turn down the volume and adjust the phase reverse control in VoiceLive 2. Return to standing position and adjust your guitar volume to the level that caused the feedback. If this didn't work, guitar monitor level or overall (guitar and vocal effects) will have to be reduced.

REVERB STYLE

The Reverb processor accurately simulates acoustic spaces around your guitar. This is an entirely separate processor from the one used for the vocal processing. It does, however, offer the same style selection but with no Style editing.

Use the Data Wheel to scroll down to this row and turn the Mix/Edit control beneath the parameter to audition the Reverb styles. There are 30 styles to choose from

covering everything from tight ambience to giant arenas. The factory default style is called SMOOTH PLATE.

REVERB LEVEL

Turn the Mix/Edit knob below this parameter to raise and lower the amount of Reverb on your guitar from the factory default of -30 dB.

UMOD STYLE

Scroll down to this row and use the Mix/Edit knob to change μ Mod (Micromod) style for the guitar. As with Reverb, this effect processor is entirely separate from the vocal μ Mod processor while offering the same style selection. No μ Mod style editing is possible for guitar.

The factory default style, MICROMOD CLONE offers a gentle stereo detune effect.

UMOD LEVEL

Turn the Mix/Edit knob below this parameter to raise or lower the amount of μ Mod effect on your guitar. The factory default mix level is -12 dB.

The Global Controls: Guitar FX

The EQ Tab

Use the Navigate arrows to tab over to the EQ tab from the GUITAR tab. Here you will find a 3 band EQ featuring:

Low band shelving

All band fully parametric peak/dip control

High band shelving

The 2 “Shelving” EQs boost or cut all frequencies below or above the the frequencies set by the LOW FREQ and HIGH FREQ controls respectively. These are most like the common Bass and Treble controls on a stereo system.

The “Parametric” EQ boosts or cuts the frequencies within a selected band that is defined by a center frequency (PARA FREQ) and a width control (PARA WIDTH). Usually, the gain of a narrow parametric band is typically reduced to overcome room or undesirable guitar resonances. This smoothes the sound and can help overcome guitar feedback.

The 3 GAIN controls allow +/- 12 dB of adjustment. The 3 FREQ controls range from 20 Hz to 20 kHz.

LOW GAIN

Boosts or cuts the range of frequencies **below** the frequency set by the LOW FREQ control.

LOW FREQ(uecy)

Allows you to define the frequency range for the low shelf by choosing the highest frequency below which boosting or cutting is possible.

HIGH GAIN

Boosts or cuts the range of frequencies **above** the frequency set by the LOW FREQ control.

HIGH FREQ

Defines the frequency range for the high shelf with the selection of the lowest frequency above which boosting or cutting is possible.

The Global Controls: Guitar FX

PARA GAIN

Boosts or cuts the band of frequencies centered at the setting of the PARA FREQ control and its associated WIDTH.

PARA FREQ

Defines the center of the parametric band.

PARA WIDTH

Defines how narrow or wide the parametric band is to be. The ends of the control range are labelled "NARROW" and "WIDE" to add meaning to the numbers in the middle of the control range.

The COMPRESS Tab

Use the Navigate arrows to tab over to the COMPRESS tab from the EQ tab. Here you will find controls for the guitar compressor. The default settings offer very gentle compression of peaks.

THRESHOLD

This sets the level at and above which the amount of gain reduction (compression) specified by the RATIO

control will occur. The range is 0 dB (not compressing any peaks) to -60 dB (compressing everything you play) with the default being -6 dB.

RATIO

This sets how much gain reduction you want when your guitar level goes above the threshold. The range is from 1:1 (no gain reduction) to 64:1 (complete flattening of peaks - also known as limiting). The number on the left side of the : (colon) symbol is how loud your guitar has to be in order to achieve a 1 dB gain increase. The default setting is 1.8:1.

Note that the RATIO control has to be set above 1.0 (1.0:1) to apply any compression regardless of the setting of the THRESHOLD.

Also note that automatic makeup gain occurs depending on your combination of THRESHOLD and RATIO. A side effect of compression is that it can reduce apparent level until makeup gain is applied to raise the overall level.

Overview

Basic editing, menu navigation and concepts are briefly discussed on page 23. This Edit Menu section discusses the actual parameters in detail for those that want to go beyond merely loading a new style in order to make changes to their sound.

Navigation

Press the Edit button to access the editing menus and make changes to the current preset. This will present the edit tabs. Press the right and left Navigate arrow buttons to cycle right and left through the tabs shown at the top of the screen. Each tab represents an effect footswitch with an additional tab for overall preset settings. Holding either arrow button jumps from the uMod tab to the FX tab.

Turn the Mix/Edit knobs to change the setting of the parameter directly above that is within the highlighted row. Up to 3 rows are visible per screen with additional rows accessible by turning the Data Wheel. A vertical scroll bar at the right of the screen shows where you

currently are in the menu.

To exit the Edit menu, press Home.

Saving Changes

You can quickly store at the current preset location from within the Edit menu by pressing the Store button twice. If you're finished editing, press Home to exit the Edit menu.

You can rename the preset and store to another location by pressing Store once and changing the values at the bottom of the Store menu. When you've edited the name and found a new place to store your edited preset, press Store again.

To cancel a Store operation from within the Store tab, press Home or Edit.

The Edit Menu: μ MOD Tab

Overview

μ Mod is short for micro-modulation (“ μ ” is the scientific symbol for micro). The μ Mod effect is capable of creating many different sounds that range from subtle but lush thickening to creatively destructive. It uses a combination of stereo pitch shifting (Detune), small amounts of stereo delay (Delay), and then a complex path of filtering, feedback, and modulation. μ Mod does a faithful job of emulating classic detune, chorus, flange and thickening sounds.

STYLE

Use the soft knob assigned to this parameter to choose a pre-programmed μ Mod style you like.

LEVEL

Sets the mix level for the μ Mod effect.

WIDTH

Normally, the output of the μ Mod effect is panned hard left and right. This parameter sets the stereo imaging of the μ Mod effect to mono (0%) and stereo (100%).

DETUNE LEFT / DETUNE RIGHT

Applies a small amount of pitch shift to the left or right sides independently. This setting is shown in cents and the maximum is +/- 25 cents.

SPEED

This setting sets how fast the delay time modulation occurs. In order for this to be audible, the depth amount parameter has to be nonzero. The setting range is 10.00 Hz (very fast) to .05 Hz (very slow).

DEPTH-L / DEPTH-R

These set the amount of modulation of the delay time for the left and right delays. If one delay is set to 10mS, for example, a setting of 50% will vary the delay time between 15mS and 5mS at the rate set by the SPEED parameter.

OUT PHASE

The OUT PHASE setting puts the output of the left and right sides of the μ Mod effect out of phase to create more 3D sound space around the effect. Note that this may potentially limit the effect's ability to collapse to

The Edit Menu: μ MOD Tab

mono. LEFT puts the left side out of phase with the right which is normal phase and vice versa for the RIGHT value. BOTH puts both sides out of phase with their respective sides' correct phase while remaining in phase with each other.

DLY L / DLY R

Sets the left and right delay times. Up to 50 ms of delay is available on the left and right delay lines to create effects from flange to slapback.

FEEDBACK L / FEEDBACK R

Re-introduces a portion of the audio output signal of the μ Mod block back to the input to create flanges, tube and chorus effects. Values above 90 add a high amount of gain and cause distortion and higher audio levels.

PHASE

This defines the modulation phase which is the phase relationship between the left and right modulation LFOs (oscillators). In a flange style, for example, setting this to 0 degrees puts all of the effect in the center while setting it to 180 degrees pulls the effect far into the stereo field.

WAVE

This lets you choose the modulation waveform from Square, Triangle or Sine to vary the periodic nature of the modulation effect.

XFL L / XFL R

These send cross feedback from the left and right delay lines (XFL L) and from right to left (XFR L). Cross feedback returns the delayed audio to the opposite side's delay line. This can produce interesting stereo effects.

LOWCUT L / LOWCUT R

HICUT L / HICUT R

These steep highpass (LOWCUT) and low pass (HIGHCUT) filters control the bandwidth of the μ Mod feedback paths. These are very useful for tailoring Flange effects.

LEAD TO UMOD

Sets the amount of lead voice sent into the μ Mod block.

The Edit Menu: μ MOD Tab

HARM TO UMOD

Sets the amount of harmony level sent into the μ Mod block. The HARMONY footswitch must be on to feed this send.

LEAD LEVEL

Controls the lead (dry + Tone) voice level when the individual effect is turned on with its respective footswitch. This allows a unique wet/dry mix for individual effects. When multiple effects are active, the lowest LEAD LEVEL value will determine the value.

Note that the LEAD EFFECT SENDS parameter on the PRESET tab must be set to PRE in order for any signal to get to the effect block when LEAD LEVEL is set to OFF.

The Edit Menu: DELAY Tab

Overview

The delay effect is a configurable echo. You can control how far apart the echoes occur (Delay Time), and whether the echoes fade out quickly or slowly or build on themselves. In addition, there are filtering and stereo controls that allow you to create many popular delay sounds. Delays can be typically be categorized into the two listed categories below:

Short Delays:

- o Initial reflections
- o Slaps

Long Delays (max stereo delay is 2500 ms or 2.5 sec.)

- o Mono taps
- o Stereo taps
- o Syncopated taps
- o Ping-pongs (delays travelling from left to right)

STYLE

Use the soft knob assigned to this parameter to choose a pre-programmed delay style you like.

LEVEL

Sets the mix level for the delay effect.

WIDTH

The 2 delay lines are panned hard left and right. This allows you to determine the stereo imaging of the delay effect. 0% is mono, 100% is fully stereo.

SOURCE

Determines which of the three methods you want to use to set delay times. These include:

TIME: This allows you to set the exact delay time for the left and right delay lines manually with the TIME L and TIME R controls.

TAP: This allows you to tap the SHORTCUT footswitch when it is assigned to TEMPO in the PRESET tab.

The Edit Menu: DELAY Tab

MIDI: The unit can be set to derive its delay times from incoming MIDI clock signal.

TEMPO

This is where you can manually set the tempo in beats per minute (bpm) that is used to derive delay times for both the left and right delay lines. The bpm value of the TEMPO parameter is only applied to the delay times when TAP or MIDI is set as the source.

DUCKING

When DUCKING is set to ON, the delay output will be reduced while you are singing. At the end of a sung phrase, the delay effects return to the level you set. This can increase the clarity of your vocals while still sounding very "wet". The amount of attenuation and attack time for the ducking to engage are set with the DUCKING AMOUNT and DUCKING TIME parameters further down in this menu.

DIV L / DIV R

When the source is set to TAP or MIDI, these parameters divide the tempo into even (e.g. 1/4 or

quarter notes) or syncopated sub-beats (e.g. 1/4 triplets, 1/4 dotted notes) for the left and right delays.

TIME L / TIME R

These parameters are used to display the exact delay time and to allow editing with all SOURCE settings. You may set from 0 to 2500ms (2.5 seconds) of delay for the left and right delay lines.

FEEDBACK L / FEEDBACK R

Re-introduces a portion of the audio output signal of the Delay block back to the input to add echo repeats.

XFB R TO L / XFB L TO R

Cross feedback returns the delayed audio to the opposite side's delay line for ping pong type effects.

LOCUT L / LOCUT R

HICUT L / HICUT R

These steep highpass (LOWCUT) and low pass (HIGHCUT) filters control the bandwidth of the delays. Applying these filters to the delays can create the feeling of space while not obscuring the main vocal signal.

The Edit Menu: DELAY Tab

DUCKING AMOUNT

This sets how much attenuation (gain reduction) is applied to the delayed signal when a vocal is present. For ducking to not be too obvious, a slight reduction of -6 dB is best. The DUCKING parameter must be set to ON for this to have any effect.

DUCKING TIME

Ducking time sets how long it takes to ramp up the delay level at the end of vocal phrases.

LEAD TO DLY

Sets the amount of lead voice sent into the Delay block.

HARM TO DLY

Sets the amount of harmony level sent into the Delay block. The HARMONY footswitch must be on to feed this send.

UMOD TO DLY

This allows you to feed the delay block with the effected output of the μ Mod block. The μ Mod footswitch must be on to feed this send.

LEAD LEVEL

Controls the lead (dry + Tone) voice level when the individual effect is turned on with its respective footswitch. This allows a unique wet/dry mix for individual effects. When multiple effects are active, the lowest LEAD LEVEL value will determine the value.

Note that the LEAD EFFECT SENDS parameter on the PRESET tab must be set to PRE in order for any signal to get to the effect block when LEAD LEVEL is set to OFF.

The Edit Menu: REVERB Tab

Overview

Reverb is the arguably the most common vocal effect. It can add a spaciousness that softens the abrupt beginnings and endings of lyric phrases. Many reverb types are meant to imitate the natural sound of spaces like churches, clubs and halls but not all. Some reverb effects are recreations of electro-mechanical effects meant to imitate real spaces like plates and springs.

Reverbs are made up of early reflections and the longer reverberant sounds known as the tails. There are usually controls to control the balance of room level and tail. Additionally, a small delay can be added between the dry voice and the reverb signal that adds clarity by briefly separating the dry voice from its reverb. By far the most important control for reverb is the level. A single reverb patch can have a different result for the audience whether it is mixed quietly or boldly in the mix.

STYLE

Use the soft knob assigned to this parameter to choose a pre-programmed reverb style you like.

LEVEL

Sets the mix level for the Reverb effect.

WIDTH

Sets the stereo imaging of the Reverb effect. 0% is mono, 100% is fully stereo.

DECAY

Sets the length of the reverb tail from 10mS to 20 seconds. Note that, due to the complex nature of Reverb algorithms, a decay time of 4 seconds may sound quiet different from one style to the next, even when the rest of the settings are identical.

LO COLOR / HI COLOR

These are preset-frequency filters inserted into the Reverb feedback path that tailor the low and high frequency response and decay of the tails. Values toward -50 will cut response in its respective band and a values toward 50 increase response.

The Edit Menu: REVERB Tab

HI FACTOR

This allows you to raise or lower the level of the high band of the Reverb tail independently.

EARLY REFLECTIONS / TAIL LEVEL

These parameters allow you to attain the right balance between reflections you would hear from close surfaces (EARLY REFLECTIONS) with those from surfaces further away (TAIL LEVEL). The settings for the early reflections in each style are slightly different but non-editable.

DUCKING

When DUCKING is set to ON, the Reverb block's output will be reduced while you are singing. At the end of a sung phrase, the effects return to the level you set, increasing the clarity of your vocals while still sounding very "wet". The amount of attenuation and attack time for ducking are set with the DUCKING AMOUNT and DUCKING TIME parameters further down in this menu.

DIFFUSE

Also known as Diffusion, this is a very subtle parameter used to simulate and control the density of the reflections inherent in real acoustic spaces. Low DIFFUSE values (-25 to 0) are intended to introduce more discrete echo-like motion to the tail where high values (0 to 25) make the tail smoother-sounding.

PRE DLY

Pre Delay introduces a short (up to 100 ms) delay between the dry audio signal and the onset of reverb to help simulate larger spaces and to provide audio separation between the dry signal and the reverb effect.

SPEED

This controls the rate of pitch modulation set by the DEPTH parameter. This modulation adds complexity and slight chorusing between the reverb tail and the input voice. The values range from -25 to 25.

DEPTH

This controls the amount of pitch modulation applied to the reverb tail. The values range from -25 to 25.

The Edit Menu: REVERB Tab

DUCKING AMOUNT

This sets how much attenuation (gain reduction) is applied to the reverb signal when a vocal is present. For ducking to not be too obvious, a slight reduction of -6 is best. The DUCKING parameter must be set to ON for this to have any effect.

DUCKING TIME

Ducking time sets how long it takes to ramp up the reverb level at the end of vocal phrases.

LEAD to REV

Sets the amount of lead level sent into the Reverb block.

HARM to REV

Sets the amount of harmony level sent into the Reverb block. Harmonies must be on to feed this send.

DEL to REV

This allows you to feed the reverb block with the effected output of the delay block. The DELAY footswitch must be on to feed this send.

LEAD LEVEL

Controls the lead (dry + Tone) voice level when the individual effect is turned on with its respective footswitch. This allows a unique wet/dry mix for individual effects. When multiple effects are active, the lowest LEAD LEVEL value will determine the value.

Note that the LEAD EFFECT SENDS parameter on the PRESET tab must be set to PRE in order for any signal to get to the effect block when LEAD LEVEL is set to OFF.

The Edit Menu: HARMONY Tab

Overview

The Harmony block in VoiceLive 2 produces up to 8 harmony voices and is the home of the Choir effect.

IMPORTANT NOTE: The parameters available on the HARMONY Tab and their organization differs depending on the value of the NATURALPLAY parameter at the bottom of the tab. This section begins by describing the most common NATURALPLAY harmony mode: AUTO INPUT SENSE. Following the parameter descriptions for AUTO INPUT SENSE, exceptions and differences for the other NATURALPLAY modes are listed.

STYLE

Use the soft knob assigned to this parameter to choose a Harmony style you like. Styles configure useful settings to pre-programmed values to allow you to make changes quickly. The selection of styles will change depending on the setting of the NATURALPLAY parameter.

LEVEL

Sets the level for the overall Harmony effect in the current preset.

VI to V4 VOICING

Here you set the pitch shift intervals of voices 1 through 4 relative to your input pitch. The names of the intervals change depending on NATURALPLAY mode. In the two MIDI NOTES modes, the VOICING parameters disappear entirely. The options start at the lowest harmony interval and go the highest.

VI to V4 LEVEL

The four knobs control the relative volume of each voice. This is also where voices are turned on or off. The range of values goes from Off to 0 dB (Full). Typically all voices are set at the same level unless you want to highlight or minimize a particular voicing interval.

VI to V4 GENDER

Each voice has its own timbre adjustment in the form of the GENDER control. Values below 0 lend each voice a more masculine and deeper effect and values above 0

The Edit Menu: HARMONY Tab

lend a more feminine or thinner effect.

VI to V4 PAN

Each voice may have a unique pan position. There are 100 possible steps in each of the left and right pan positions. Note that the Setup parameter: OUTPUT must be set to STEREO in order to hear the panning effect.

DOUBLING and DBL LEVEL

This can thicken the sound of your harmony voices by engaging a doubled version of each voice. The doubled voices are lightly humanized with modifications of the current HUMANIZE STYLE values in order to produce a doubled voice effect rather than simply adding level. When the value of either the HUMANIZE STYLE or AMOUNT is Off or 0 respectively, the doubled harmony voices are still slightly humanized. The level of the doubling voice is dependent on the level of each harmony voice, then by the overall doubling level parameter; DBL LEVEL.

CHOIR, CHOIR LEV and CHOIR STYLE

The Choir effect strives to emulate the detuning, timing and chorusing that occurs when human voices sing together in choral performances and recordings. The Choir effect is applied to the Harmony voices and the Harmony Doubling and Double voices if they are active. CHOIR ON/OFF activates the style and level set by the CHOIR STYLE and CHOIR LEV parameters respectively. To create a convincing choir performance, it helps to sing legato (sustained) phrases as opposed to staccato or melismatic riffs.

HUMANIZE STYLE

The term “humanize” simply means the application of processes designed to increase realism. All harmony modes usually benefit from careful application of humanization styles that make each harmony voice respond with small pitch and timing variations different from your voice. Each Humanize Style configures each of the four voices differently; Voice 1 has slightly different parameter values than say Voice 4 in the same style but all four voices will work together to produce a useful overall effect.

The Edit Menu: HARMONY Tab

The various Humanization styles consist of various amounts of the following modifiers:

- o Onset pitch events - This is also known as “scooping” which adds a generated pitch trajectory for each new note that is different than the sung note.
- o Pitch modulation - a random wave generator wobbles the pitch in non-periodic ways to simulate even the finest singers’ pitch variation.
- o Timing delay and modulation - Singers are unable to start notes at the same time with the exactness of a machine so this algorithm applies slight delays to the onset of notes and then adds modulated time variation to sustained portions of notes.
- o Level (volume) modulation - This effect is like a subtle tremolo with a non-periodic or semi random waveform that simulates the way different singers change note volumes as they sing.

HUMANIZE AMOUNT

You can vary the amount of humanization for the harmony voices. All the styles except for the last one: TIME & PITCH were designed at middle values to allow you to add or remove effects as you see fit. TIME & PITCH was designed so you can create wild special effects as you experiment with high values.

VIBRATO STYLE

Vibrato assists in providing separation between your dry singing voice and the harmonies as well as to add some movement to the rigid pitch contour in MIDI NOTES mode harmony. Even the smallest amount of vibrato applied to your harmony voices can achieve this. Like the HUMANIZE effects, each voice is treated slightly differently by the VIBRATO algorithm so the voices don't all sound exactly the same. There are 7 styles available in progressively more intensity as you browse down the list.

VIBRATO AMOUNT

You can vary the amount of vibrato intensity for the overall style with this parameter. All the styles were

The Edit Menu: HARMONY Tab

designed to be useful at middle values but you can add or remove vibrato as you like.

VI to V4 PORTA

Each voice has its own Portamento time. Portamento is a delayed response to the pitch movement of your singing voice. It is also referred to as “Glide” in synthesizers. The range of values equals approximately how long the upwards or downwards slide will take to reach each new note. Setting each voice to different values greatly assists the illusion of other singers singing with you.

VI to V5 SMOOTHING

At low values, Smoothing acts like pitch correction for the harmony voices. With the voices corrected like this, some Portamento is usually required to help soften note to note transitions unless a robot-like effect is desired. Higher values offer progressively less correction. Like Portamento, setting each voice with a unique value of the Smoothing parameter helps the harmonies sound more natural. When NATURALPLAY is set to MIDI NOTES, high values of smoothing will sound out of tune.

GUITAR CHORDS

This parameter changes the harmony note response to DOM7 guitar chords only. At the default setting; ACCEPT DOM7, whenever you play a dominant 7th chord and the combination of your singing note and harmony voicing is set to produce a 7th harmony, you'll hear the 7th.

In a song composed largely of DOM7 chords, it's not that easy to sing a melody composed of all of the 7ths and thus, many harmony singers move to the chord root instead. Broadly speaking, this is also a difference between a “Pop” sounding harmony and a more “Bluesy” harmony sound. This is what the IGNORE DOM7 setting does.

HOLD REL

Hold Rel (Hold Release) varies the amount of time it takes for any notes held with the Hold feature to decay. This makes for a more natural release. Note that no new harmony notes will sound until the time you set with this parameter has elapsed.

The Edit Menu: HARMONY Tab

TUNING

The Tuning parameter allows you to affect tiny pitch adjustments to your harmony intervals to achieve Equal, Just or Barbershop tuning. Each preset can have a different value for TUNING.

Equal tuning is the “compromised” tuning standard that instruments such as guitar and keyboards are designed to produce. This tuning mode allows you to play and sing in any key without completely retuning your instrument for every chord. When your harmonies are set to this mode, the harmony notes produced by VoiceLive 2 will sound exactly in tune with the Equal-tuned instruments you use for accompaniment.

Just tuning is what is known as “perfect” intonation between your lead voice and harmony intervals. This is the tuning that occurs when singers sing a cappella, or without instruments. The pitches of major and minor thirds, fifth intervals and others are brought into exact mathematical symmetry with your lead voice by introducing very small pitch shifts to the harmonies which overcomes the slight “beating” of harmonics that occurs

with Equal tuning mode. Because of this, however, the harmony intervals may sound infinitesimally out of tune with your instrument.

Barbershop has the same tuning offsets as Just tuning mode with one difference. Barbershop tuning uses **your singing voice** as the pitch reference where Just intonation uses the root of the current chord played via MIDI.

HARMONY EQ

The Harmony EQ settings are separate from the Global TONE control. This allows customizing of the EQ of the Harmony and Double voices separately from the lead. For a description of the EQ controls, see the Global TONE parameter description when MANUAL is ON.

LEAD LEVEL

Controls the lead (dry + Tone) voice level when the individual effect is turned on with its respective footswitch. This allows a unique wet/dry mix for individual effects. When multiple effects are active, the lowest LEAD LEVEL value will determine the value.

The Edit Menu: HARMONY Tab

Note that the LEAD EFFECT SENDS parameter on the PRESET tab must be set to PRE in order for any signal to get to the effect block when LEAD LEVEL is set to OFF.

NATURALPLAY

This parameter defines how VoiceLive 2 derives the musical information that makes the harmony voices follow your song. The most common value for this is AUTO INPUT SENSE which automatically decides which of the GUITAR IN, MIDI IN and AUX IN you are currently playing into so it can derive musically correct harmonies. Changing the value of this parameter changes the number and organization of settings in the HARMONY tab. The values are described below:

- o AUTO INPUT SENSE - Most harmony presets are based on this mode. This mode automatically decides which of the GUITAR IN, MIDI IN and AUX IN you are currently playing so it can derive musically correct harmonies from that input.
- o GUITAR - This forces the current preset to look only to the GUITAR IN for musical input. In the

case where you have a MIDI sequencer and guitar into VoiceLive 2, this will cause it to ignore the MIDI input for harmony control.

- o MIDI - This forces the current preset to look only to the MIDI IN for musical input. In the case where you have a MIDI sequencer and guitar into VoiceLive 2, this will cause it to ignore the guitar input.
- o AUX INPUT - Harmonies will ignore all but this input if the other inputs are used simultaneously.
- o SCALE - Changes the preset to scale mode which will ignore ongoing musical input from an instrument in favour of the Key and Scale setting you need to input. Scale harmonies are a great alternative to instrument-controlled harmony for certain songs.
- o SHIFT - Many doubling presets that also use the Harmony block are based on this mode. SHIFT allows you to pick pitch shift intervals that fall outside of the standard "musical harmony"

The Edit Menu: HARMONY Tab

definition and as such, require no musical input from you.

- o MIDI NOTES - Allows you to specify exact melodies and chords as harmony pitches from a MIDI keyboard or sequencer. A MIDI note held during a sung arpeggio will not move until the note is changed. As well, a single, sustained input note from you can have a moving harmony arpeggio by playing it on a keyboard. This mode is for people who want to arrange their harmony vocals exactly and have keyboard playing skills. When set to NOTES, the Harmony DOUBLING parameter determines interesting layering of the 8 available harmony voices.
- o MIDI NOTES 4 CHAN - This is the same as MIDI NOTES mode with the difference that each of the four harmony voices has its own MIDI channel. This is best when you want the harmony voices to have fixed pan positions and MIDI pitch bend movement.

Non-NATURALPLAY Parameter Changes

Below are descriptions of parameters that are different when set to the NATURALPLAY modes other than AUTO INPUT SENSE, GUITAR, MIDI and AUX INPUT which are identical except for the input device. The parameters that disappear are not listed. Note that each of the following modes has it's own unique Style selection.

NATURALPLAY = SCALE Mode

KEY & SCALE

This parameter and the SET KEY shortcut (if assigned as such) set a fixed key and scale that fits your music. A custom scale can also be selected where the relationship of each harmony voice to a given input note can be defined by you. In the majority of presets, the default custom scale is defined to give drone notes based on the selected key.

VI to V4 VOICING

The voicing alternatives change in SCALE mode and

The Edit Menu: HARMONY Tab

they are displayed in scale degree terminology. They are organized lowest to highest, relative to the input note.

MAP IN SOURCE / MAP IN NOTE

These allow to customize individual harmony note intervals relative to your input note and create a custom scale. A custom scale is not share-able with other presets until the preset is copied to another location.

To customize a scale, pick a key and scale closest to what you want for your song. Sing the note you upon which you want the harmony interval to change (MAP IN SOURCE set to SUNG) or select it with the MAP IN NOTE parameter (MAP IN SOURCE set to MANUAL). Now you can change the harmony interval with the MAP IN NOTE parameter described below.

VI to V4 MAP OUT

Sets the interval relationship between each of the four harmony voices for the current input note and key and scale settings. Typically, incrementing or decrementing any active harmony voices can make a scale work over your combination of melody and chord change.

NATURALPLAY = SHIFT Mode

VI to V4 VOICING

The voicings for Shift mode have no musical intelligence and as such will produce harmony a fixed, unmoving interval away from your lead voice. You can select any semitone interval from -24 semitones to +24 semitones. They are organized lowest to highest, relative to the input note.

NATURALPLAY = MIDI NOTES, MIDI NOTES 4 CHAN Modes

DOUBLING

This changes from an ON/OFF parameter to a selection of the number of voices you can control via MIDI.

- o OFF - No harmony voice doubling is possible but you have access to 8 unique MIDI note intervals upon which to build harmonies.
- o ON (4 VOICES X2) - With this you can play up to 4 voices at once, but each voice can be doubled for extra thickness.

The Edit Menu: HARMONY Tab

- o UNISON - All 8 voices are triggered from a single MIDI note. This is similar to a synthesizer mode of the same name where you can layer all voices on one note.

ATTACK / RELEASE

These settings are designed to introduce fade ins and fade outs to the harmony voices. The Attack parameter provides a gentle volume fade-in when you strike a MIDI note during a sustained sung note. The Release parameter adds a smooth fade-out if you release your MIDI note as you continue to sing. The values range from 0 to 1000 milliseconds for the Attack and 0 to 2000 ms for the Release.

NOTES EXT

This feature is most useful when singing to a commercial MIDI file that is controlling the harmony voices in VoiceLive 2. Often the MIDI notes used to control harmony cut off where the singer might prefer to hold the notes longer and this makes for a more

singer-oriented MIDI performance. The Notes Extension setting allows a harmony voice that has been triggered in Notes mode to continue sounding while the singer sings a sustained note after the MIDI note has ceased.

NATURALPLAY = MIDI NOTES Mode only

GENDER, PAN, PORTA, SMOOTH, and Voice LEVEL

The ability to control voices individually is removed in MIDI NOTES mode to simplify and reduce the number of parameters required when 8 voices are active. In their place are macro-type settings for the features listed above. For individual control of 4 MIDI voices, you can use MIDI 4 CHAN mode.

The Edit Menu: **DOUBLE** Tab

Overview

The Double effect uses the same type of Humanization technology as in the Harmony effect to create up to four overdubbed versions of your voice. The four voices are set to unison intervals as opposed to the move-able intervals available for the harmony voices. Unlike simple detune or micro-shift techniques available with the μ Mod effect, Double simulates the sound of a vocalist overdubbing their vocal part multiple times. Many of the edit parameters for the Doubling tab are the same as for Harmony tab.

STYLE

Use the soft knob assigned to this parameter to choose a pre-programmed Double style you like. This allows you to quickly choose an effect close to what you want instead of having to go directly into the individual parameters each time.

LEVEL

Sets the level for the overall Double effect in the current preset.

HUMANIZE STYLE

These apply small pitch and time variations to simulate natural variation in human singing. For more information see HUMANIZE STYLE in the HARMONY Tab section preceding.

HUMANIZE AMOUNT

Increases or decreases the amount of Humanize variations to the Double voices only.

VI to V4 PAN

Each voice may have a unique pan position. There are 100 possible steps in each of the left and right pan positions.

VI to V4 LEVEL

These settings control the volume of each of the voices and are used to set the number of voices active for Doubling. The range of values goes from Off to 0 dB (Full).

VI to V4 PORTA

Each voice has its own Portamento time. Portamento is a

The Edit Menu: **DOUBLE** Tab

delayed response to the pitch movement of your singing voice. It is also referred to as "Glide" in synthesizers. The range of values equals approximately how long the upwards or downwards slide will take to reach each new note. Setting each voice to different values greatly assists the illusion of other singers singing with you.

VI to V4 SMOOTHING

At low values, Smoothing acts like pitch correction for the harmony voices. With the voices corrected like this, some Portamento is usually required to help soften note to note transitions unless a robot-like effect is desired. Higher values offer progressively less correction. Like Portamento, setting each voice with a unique value of the Smoothing parameter helps the harmonies sound more natural.

VI to V4 GENDER

Each voice has its own timbre adjustment in the form of the GENDER control. Values below 0 lend each voice a more masculine and deeper effect and values above 0 lend a more feminine or thinner effect.

LEAD LEVEL

Controls the lead (dry + Tone) voice level when the individual effect is turned on with its respective footswitch. This allows a unique wet/dry mix for individual effects. When multiple effects are active, the lowest LEAD LEVEL value will determine the value.

Note that the LEAD EFFECT SENDS parameter on the PRESET tab must be set to PRE in order for any signal to get to the effect block when LEAD LEVEL is set to OFF.

The Edit Menu: FX Tab

Overview

The FX tab contains the edit settings for a combination of two effects:

- Transducer, which uses distortion and steep filters to emulate the sound of radios, phones and devices that generally degrade the audio signal.
- HardTune, which is a pitch corrector that has been optimized to produce corrective pitch correction as well as obvious effects made popular by a number of artists.

Both effects can be used simultaneously or independently.

TRANSDUCER

This parameter turns the Transducer effect on or off for the current preset.

ROUTING:

Selects where the Transducer effect is inserted into the signal path for maximum flexibility. The options are:

- OFF - No routing.

- LEAD - Transducer is inserted on the Lead voice only. Harmonies and Doubling are unaffected.
- HARMONY - Transducer is inserted on the Harmony path only.
- VOICES - Transducer is inserted on both the Lead, Harmony and Doubling voices.
- LEAD FX - Transducer is inserted on the Lead send to the μ Mod, Delay and Reverb effect sends. Lead voice will be clean and the effects will be affected by the Transducer style.
- HARM FX - transducer is inserted on the HARMONY send to the effects. Lead and Harmony voices will be clean but the effects driven by only the Harmonies will be affected by the Transducer style.

TRANSDUCER STYLE

Use the soft knob assigned to this parameter to choose a Transducer style you like. The Routing and Gate Threshold parameters are not part of the style.

The Edit Menu: FX Tab

LOW CUT and HIGH CUT

Sets the cut-off frequency for these very steep low and high shelving filters. TIP: these and the PRESENCE filters can be used without Distortion effects to apply more radical EQ to your presets.

GATE THRESHOLD

A gate, separate from the main Gate under the Tone button is used to help prevent feedback when using the Transducer with heavy distortion or presence filtering that can introduce feedback in a live environment. This parameter sets how loud you must sing in order to open the gate.

DISTORTION TYPE and DISTORTION AMOUNT

These are pre-configured distortion styles that range from Overdrive through Saturation and Distortion and finally, Fuzz. Each has a unique character. Though these styles have no detailed controls like the Delay or Reverb tabs for example, you can add or reduce the distortion component and apply filtering with LOW CUT, HIGH CUT, and PRESENCE to customize them.

The AMOUNT parameter adjusts the amount of distortion for the current distortion style. This is not the same as the IN and OUT GAIN controls which work on level adjustment. The Distortion Amount control adjusts the algorithmic distortion curve that you can further trim with the TRANSDUCER IN GAIN and TRANSDUCER OUT GAIN controls.

Note that your IN GAIN in the Setup menu must be sufficient in order to hear the correct amount of distortion present in distorted styles.

TRANSDUCER IN GAIN and TRANSDUCER OUT GAIN

These act similarly to a guitar distortion pedal or an amplifier with input gain and master level controls. IN GAIN boosts or attenuates the amount of distortion for the distortion type selected.

When you adjust the IN GAIN parameter, just like a guitar amplifier, the overall level of the effect goes up and down. Use the OUT GAIN control to adjust the output level of the Transducer block to properly balance

The Edit Menu: FX Tab

the current preset with the others.

PRESENCE GAIN, PRES FREQ and PRES WIDTH

The parametric EQ allows a peak/dip filter to be added to help emulate the sonic characteristic of various speakers such as a megaphone which has a very narrow mid peak. GAIN adjusts the amount of boost or attenuation while FREQ sets the center frequency of the filter. WIDTH sets how narrow or wide the filter will be set. Note that excessive boost of certain narrow frequencies can induce feedback with even the best monitor equipment and placement.

HARDTUNE

Turns the HARDTUNE pitch correction effect on or off.

HARDTUNE RATE

RATE determines how fast the algorithm pulls you toward scale tones. A value of 0 is off and a value of 100 is instant resulting in something like the infamous “Cher” effect where the pitch correction effect is stair-stepped and obvious when using non-chromatic scales (those

with at least a whole-tone jump between most of the scale tones). Usually, values around 20 yield acceptable results for smooth, corrective pitch correction.

HARDTUNE KEY

Sets HardTune's source for musical information. Most pitch correction products require either scale information, offline editing or MIDI performance to yield correction. VoiceLive 2 goes one further and allows you to play your guitar or MIDI keyboard normally and get the result.

When set to FOLLOW HARMONY the HardTune effect will follow the same source as the harmony voices. For example, if a guitar is controlling your harmony voices, it would also control your HardTune effect. When the parameter is set to MANUAL/CUSTOM the Key and Scale are set with the KEY and SCALE parameters lower down in the FX tab.

When FOLLOW HARMONY is set for HARDTUNE and the Harmony NATURALPLAY mode is set to SCALE, then only the key is passed on to the

The Edit Menu: FX Tab

HARDTUNE effect. This allows a different scale to be used for the HardTune effect independent of the Harmony effect. When Harmony is set to SHIFT, MIDI NOTES, or MIDI NOTES 4 CHAN, HardTune will use its own key and scale parameters.

HARDTUNE SHIFT

Sets the a relative shift in semi-tones above or below the input vocal. This is useful for transposing or creating character voices while simultaneously pitch correcting.

HARDTUNE AMOUNT

Allows you to soften the correction effect. A value of 50% for example will only pull you halfway toward a correction scale target at the speed set by the HARDTUNE RATE parameter. For a true HardTune sound, set it to 100%

HARDTUNE WINDOW

Allows you to determine how close to a valid scale note you have to be before the algorithm corrects you. For example, a value of 80 cents means that only when you are singing within +/- 40 cents away from the target

scale note will you be corrected. The maximum value is 200 cents which, in a Major scale having no more than 100 cents on either side of any scale tone, would result in fulltime correction activity. The maximum value is ****600**** cents. At maximum, a custom scale could be created with only one note for special effects. In a Major scale having no more than 100 cents on either side of any scale tone a setting of 200 would result in fulltime correction activity

KEY / SCALE

These set the musical map that the HardTune effect will correct to. They are applied when HARDTUNE KEY is set to MANUAL/CUSTOM. When the current preset is based on Scale Harmony and HARDTUNE KEY is set to FOLLOW HARMONY these will display the key set in the HARMONY tab. The manual scale selection is different from the ones available for Harmony. They are:

- o Major
- o Minor-Har (harmonic minor)

The Edit Menu: FX Tab

- o Minor-Nat (natural minor)
- o Minor-Asc (ascending melodic minor)
- o Chromatic (no key or scale required)

NOTE / ENABLED

These are applicable when you wish to edit a custom scale for HARDTUNE. A custom scale is indicated by a series of dashes and circles: “-” and “o”. Each of these symbols represents where a note is in the correction scale or not. You can change the custom map by selecting a note you want to be corrected to or to jump over with the NOTE parameter and setting its ON or OFF status with the ENABLE parameter. You’ll see an indication of your custom scale with “o” representing notes that are enabled, and “-” showing notes that are disabled. For example “o-o-oo-o-o-o” would represent a major scale in any key (the octave up note is implied by the root note).

The Edit Menu: RHYTHMIC Tab

Overview

Using the Rhythmic features, tap tempo can control effects on the lead voice, harmonies and doubling voices in time with your music. The RHYTHMIC menu is organized into three main collections of rows:

The first two rows in this menu control the waveform modulation type effects aka Rhythmic Stutter and Rhythmic Gender.

The next two rows control short duration sample looping effects known as Rhythmic Sample.

The last row offers a fun, tap tempo synchronized cowbell sound and a useful pattern audition feature.

Using the Rhythmic features

1. Select a Rhythmic-based preset. There are example Rhythm presets available via download within the VoiceSupport application if you can't find any in the factory presets.
2. Set a tempo you want by holding the DELAY button for a moment then tapping 1/4 notes on

the DELAY button in your tempo.

3. Sing a sustained note or a legato melody.
4. Press the SHORTCUT button while continuing to sing to enable the Rhythmic feature when required. Some presets may have Rhythmic enabled.

Note 1: You can re-synchronize the beat of the Rhythmic effect or restart the pattern each time you press the SHORTCUT switch setting to ON. However, this does not apply to SAMPLE and SAMPLE MOMENT assignments.

Note 2: When SAMPLE or SAMPLE MOMENT are assigned to the SHORTCUT, the footswitch should be pressed while you are singing to feed into the loop.

Rhythmic Stutter/Gender Section

STYLE

Here are is a small collection of pre-authored Rhythmic effects. Ensure that the DEPTH is greater than 0 and RHYTHM is ON to audition the different styles.

The Edit Menu: RHYTHMIC Tab

DEPTH

Sets the intensity that the Rhythmic settings have on the Target.

1/8 DOT	1/8	1/8 TRIP
1/16 DOT	1/16	1/16 TRIP
1/32 DOT	1/32	1/32 TRIP

TARGET

Determines what Rhythmic modifies. These include:

LEAD LEVEL	GENDER, (Lead only)
LEAD PAN	HARM LEVEL,
HARM PAN	L+H LEVEL (Lead and Harmony)
L+H PAN	

RHYTHM

Turns the effect on and off. Note that this can be assigned to the SHORTCUT button in the PRESET tab for easy access in performance.

DIVISION

Sets how many cycles of the TYPE waveform occur during the bar or the elapsed time over a number of beats.

8 x 1/4	7 x 1/4	6 x 1/4	4 x 1/4
1/2 DOT	1/2	1/2 TRIP	
1/4 TRIP	1/4 2-DOT	1/4	1/4 TRIP

TYPE

Defines the rhythm. At the beginning of the list are the single repeated waveforms which range from SQUARE to SAWTOOTH DOWN. The SAMPLE AND HOLD option produces a random value on every beat division. Following these are the synchopated one bar patterns. When a synchopated pattern is selected, the DIVISION value shows N/A.

Rhythmic Sample Section

Divisions of the Tap Tempo beat can be sampled and repeated to create coarse-to-fine, short duration looping effects.

SAMPLE LOOP DIVISION

Sets the repeating length from quarter notes to finer resolutions.

1/4	1/4 TRIP
-----	----------

The Edit Menu: RHYTHMIC Tab

1/8 DOT	1/8	1/8 TRIP
1/16 DOT	1/16	1/16 TRIP
1/32 DOT	1/32	1/32 TRIP

SAMPLE LOOP CAPTURE

When set to START, you must press the Shortcut button immediately before you sing. When set to END, you can press the Shortcut button at the end of your sung phrase.

SAMPLE DIRECTION

Samples can play forward or reverse. This effect is most noticeable on longer duration samples.

PATH

When this is set to POST, the captured sample will be a composite of all effects that were on when it was captured. When set to PRE the sample is captured dry but effects can be added and removed as the sample continues to loop.

Additional Rhythmic Features

These features help you to co-ordinate the timing of

your singing with the rhythmic effects.

COWBELL

Turning this feature on produces a metronome-type cowbell sound to give an audible indication of the current tempo. This is also a possible SHORTCUT parameter so you can access it live.

LEVEL

Volume control of the cowbell sound.

PATTERN AUDITION

Allows you to hear a tone playing when the TYPE is set to a pattern. This allows you to hear the patterns without singing.

Note that the COWBELL and PATTERN AUDITION sounds are bussed into the Guitar audio path. As such, they will not produce sound if GUITAR MUTE in the I/O tab in the Setup menu is on. A side benefit is that, if you'd like to use the cowbell sound in performance, any effects you select in the Guitar FX menu will be present on the cowbell also.

The Edit Menu: PRESET Tab

Overview

This tab contains parameters that don't pertain to the other tabs.

LEAD LEVEL

This allows the overall lead (dry with Tone) voice level to be reduced for the current preset. There are additional LEAD LEVEL parameters in the effect tabs (uMOD, DELAY etc) which may be used to reduce lead level further but only when their respective effect is active.

LEAD PAN

Sets where your lead voice appears in the stereo field for the current preset. This can be useful when panning a Harmony voice to one side and your Lead voice to the other.

LEAD EFFECT SENDS

When set to PRE, your voice will be sent at a fixed level to the uMOD, DELAY and REVERB effects regardless of whether the LEAD LEVEL setting is reduced or off. When LEAD LEVEL is off and LEAD EFFECT SENDS is

PRE, 100% wet effects can be achieved if desired. When set to POST, effect levels follow the LEAD LEVEL value so the effects stay in balance with your voice when its level is reduced.

SHORTCUT

Each preset in VoiceLive 2 can have a unique Shortcut which can extend your control of effect features. Choose from the selections and save to your current preset. Note that not all may apply e.g. Harmony Hold may not work unless you have Harmony turned on.

EXPR-PEDAL

Sets the Expression pedal target for the current preset when GLOBAL EXPR-PEDAL in the Setup tab is set to OFF (Preset).

HARMONY + DOUBLE LEVEL	DELAY + REVERB LEVEL
HARMONY LEVEL	DOUBLE LEVEL
UMOD LEVEL	DELAY LEVEL
REVERB LEVEL	LEAD LEVEL
uMOD/DLY/REV LEVEL	OUTPUT LEVEL
GUITAR LEVEL	AUX LEVEL
DELAY SEND LEVEL	REVERB SEND LEVEL
RHYTHMIC DEPTH	RHYTHMIC DIVISION

The Setup Menu: I/O Tab

IN GAIN

Sets and displays the MIC / LINE input level. Both inputs share the same gain settings and are not meant to be used simultaneously; switching from a Mic to a Line level signal will likely require resetting IN GAIN. To set input level automatically, use the AUTO MIC-GAIN function by pushing and holding the REVERB footswitch and following the prompts. When any digital input is selected (USB or SPDIF) the IN GAIN does not control the digital input level. Use your transmitting device to adjust level.

PHANTOM

Turns 48V phantom power on and off for use with condenser microphones. Note that Voicelive 2 stores a different IN GAIN for PHANTOM ON and OFF states. This is ideal as it unlikely a condenser and dynamic microphone will ever require the same IN GAIN for a single singer.

AUX LEVEL

Set the input level of for the Aux input.

OUTPUT

The configures the outputs to be STEREO (default), MONO or DUAL MONO. The STEREO option outputs discrete Left and Right audio material when connected to a stereo monitor or PA system.

In MONO mode, the Left output is the summed mono mix of VoiceLive 2 including effects. The Right output is dry with only Tone applied to the MIC or LINE input signal. This is useful when a live sound engineer wants to control the balance of wet/dry mix at the mix position. In this case, set LEAD MUTE to ON.

In DUAL MONO mode, the effected vocal comes from the left output and effected guitar is produced from the right output. This allows you to have a sound tech control the level balance between wet vocal (vocal with harmonies and effects) and wet guitar.

DIGITAL IN

Selects between SPDIF and USB physical inputs as the input and also specifies where the incoming digital signal is routed. By default the routing is USB: STEREO, where

The Setup Menu: I/O Tab

the digital input is routed to the same path as the AUX input, but is not passed on to the digital output.

When set to USB: VOX L / INST R, or S/PDIF: VOX L / INST R the digital input replaces the analog MIC/LINE and GUITAR inputs and the MIC and GUITAR IN connections are disabled.

Sample rate is synchronized automatically to the incoming digital audio stream. There is no sample rate adjustment in VoiceLive 2. When processing an analog input such as the MIC and sending to VoiceLive 2's digital out, sending a short bit of audio from your recording application to either Digital input will set the sample rate.

When DIGITALIN is set to USB (or SPDIF): STEREO, harmonies will follow the stereo audio coming from the selected digital input on presets where NATURALPLAY is set to AUX INPUT.

While the VoiceLive 2 is connected via USB to your computer, other applications such as your browser may not make sound through your regular sound card. In this case, disconnect VoiceLive 2's USB cable.

DIGITAL OUT

Configures the digital output between the stereo mix of VoiceLive 2 (FULL MIX), and separated, dry outputs used for recording (VOCAL & GUITAR).

See the section Connecting VoiceLive 2 to a Computer for more details on recording procedures with these digital I/O options.

LEAD MUTE

Turns the lead voice off in all presets. This is useful in the live sound engineer setting described above or when VoiceLive 2 or is being fed by an aux send from a mixer channel where the lead level is mixed in at the mixing console.

LEAD DLY

When set to NONE (default), the lead voice is sent through VoiceLive 2 with the shortest possible latency inherent to the system. When set to VOICE SYNC, the lead voice is delayed slightly to synchronize with the processing latency of the harmony voices.

The Setup Menu: I/O Tab

OUTPUT LEVEL RANGE

Configures the maximum stereo analog output (XLR, ¼" and headphone) level. Set this value to MIC or LINE when connecting to mic or line level inputs on a mixer respectively. This will minimize distortion and noise.

The +6 and +12 options raise the respective output levels by reducing internal headroom. If you hear distortion on singing peaks when otherwise connected correctly (MIC level output to a mic input, LINE to a line input), use a lower level output option.

Note that the LINE +12 option is the highest output level and it is effective for increasing headphone output level in loud environments.

GUITAR MUTE

Mutes the guitar signal in the main outputs when no jack is connected to the GUITAR THRU jack. This allows the guitar dry signal to be mixed externally. The guitar signal still feeds the NATURALPLAY harmonies and tuner.

PAN

Sets the stereo position of the dry guitar signal.

MIC/LINE PHASE

Selects between NORMAL and INVERTED to help reduce feedback in live performance. This feature is intended to work with low and low mid frequency feedback tones. The mic must be in a stationary position in relation to the monitor.

The Setup Menu: MIDI Tab

CHANNEL

Sets the MIDI channel that VoiceLive 2 uses for presets and MIDI harmony control. When a NATURALPLAY preset is set to MIDI NOTES 4 CH, the channel selected is the channel used for VOICE 1. The MIDI channel for VOICE 2 is the selected MIDI channel + 1, VOICE 3 is +2, VOICE 3 is plus 3.

FILTER

Allows MIDI Program Change or System Exclusive messages to be ignored for convenience.

CC CHAN

Sets a separate MIDI channel for CC control if desired.

TRANSPOSE

This transposes the harmony voices in MIDI NOTES mode to allow it to be controlled by upper or lower sections of a MIDI keyboard if required. The value corresponds to octaves.

SPLITDIR

(Split Direction) Sets whether MIDI notes ABOVE

or BELOW the split point are used to control MIDI NOTES presets only.

SPLITNOTE

Sets the MIDI note above or below which the keyboard split will be active.

SYSEXID

(MIDI System Exclusive ID number) When addressing multiple VoiceLive 2 units on the same MIDI In/Thru chain with a Sysex editor, each one should have its own ID or they all will be edited in the same way.

VIBBOOST

Specifies how the Mod Wheel message affects vibrato if it is enabled in a preset. The Boost setting (default) will add more vibrato once the part of the wheel movement reaches the corresponding amount of vibrato and then returns to the original amount at rest position. The Manual setting allows full range control of vibrato once the wheel is moved. To restore the factory vibrato amount, recall the preset.

The Setup Menu: MIDI Tab

PBRANGE

(Pitchbend Range) Sets the range in semitones that MIDI pitch bend information will alter voice pitch shifts.

The Setup Menu: **SYSTEM** Tab

LCD CONTRAST

Sets the contrast level of the LCD display. Useful for better viewing at different angles and light conditions.

USB CONTROL

Setting this parameter ON should only be done when USB is connected. When this is ON, the MIDI in and out connectors are disabled and instead, MIDI is routed in and out via the USB connector only. When USB CONTROL is set to OFF, MIDI is disabled over USB and instead, the MIDI in and out connectors function for MIDI.

GLOBAL NATURALPLAY

When this parameter is enabled it forces all harmony to a predefined NATURALPLAY mode for all presets. This is for use when multiple inputs are used simultaneously yet only one is to be accepted for harmony control. The default for this parameter is OFF.

GLOBAL KEY/SCALE

When this parameter is ON (default), the Key and Scale set for a NATURALPLAY SCALE preset affects all presets. This allows you to browse SCALE presets

without having to change Key every time. In this mode, Key and Scale settings are not saved with a STORE action. When set to OFF, key and scale is configurable per preset.

GLOBAL SHORTCUT

When enable, GLOBAL SHORTCUT assigns the same shortcut to all presets. Note that setting all to one depends on whether certain conditions are met e.g. HARMONY HOLD won't work unless Harmony is on.

GLOBAL TAP TEMPO

When set to ON, all presets with Delay SOURCE set to TAP will share the same tempo. When set to OFF (default), the preset's tempo is recalled with a preset but can be changed via TAP.

TUNEREF

This sets the overall tuning reference with respect to A-440.

MOMENTARY ON

Globally sets the activation of HARMONY, DOUBLE or both to momentary. NONE returns to latching behaviour.

The Setup Menu: EXPRESSION Tab

Overview

Connecting an expression pedal such as a TC-Helicon Express 1 allows you to modify preset or global settings from a standing position using a standard volume or expression pedal.

Supported Pedal Types

Both common types of sweep type (or “treadle”) pedals can be used with VoiceLive 2:

- o Guitar-type volume pedal (2 conductor cable)
- o Keyboard-expression pedal (3 conductor cable)

Connections

Guitar-Type Volume Pedal

Connect a standard guitar cable from the Output (or To Amp) jack of the volume pedal to the PEDAL input on the back of VoiceLive 2. It's not necessary to make a connection to the Input of your volume pedal.

Keyboard-Type Expression Pedal

If you are using a keyboard type expression pedal, connect a 3 conductor cable (or the cable built into the pedal) to the PEDAL input on VoiceLive 2.

Pedal Setup

VoiceLive 2 needs to be calibrated so that your pedal's full range can be used properly. Calibration is stored even when the product is powered down so, as long as you use the same pedal, calibration need only be performed once.

To Calibrate The Expression Pedal

1. Press Setup and then navigate to the EXPRESSION tab. The Setup button will flash.
2. Follow the prompts in the display to set the minimum and maximum extents of your pedal.

When successful, the display will show the values of the various positions of the pedal you stop at.

The Setup Menu: EXPRESSION Tab

Assigning The Expression Pedal

The pedal can now be set to control any of the following parameters:

HARMONY + DOUBLE LEVEL	DELAY + REVERB LEVEL
HARMONY LEVEL	DOUBLE LEVEL
UMOD LEVEL	DELAY LEVEL
REVERB LEVEL	LEAD LEVEL
μMOD/DLY/REV LEVEL	OUTPUT LEVEL
GUITAR LEVEL	AUX LEVEL
DELAY SEND LEVEL	REVERB SEND LEVEL
RHYTHMIC DEPTH	RHYTHMIC DIVISION

To assign the pedal globally (affects all presets), choose a value with the knob below the GLOBAL EXPR-PEDAL parameter in the EXPRESSION tab of the Setup menu.

To assign the pedal per preset:

1. Ensure that the GLOBAL EXPR-PEDAL value is OFF in the EXPRESSION tab of the Setup menu.
2. Load a preset in which you would like to assign the expression pedal and press the Edit button.
3. Navigate to the PRESET tab

In the PRESET tab, turn the knob below the EXPR-PEDAL parameter to assign any of the parameter options to the expression pedal in that preset. Press Store to save the preset. Any preset can have a unique assignment of the expression pedal.

Expression Pedal Notes

When viewing the main mix screen with the expression pedal connected, the VOICES or DELAY/REVERB value is shown as EXPR when the pedal is assigned to HARMONY + DOUBLE LEVEL or DELAY + REVERB LEVEL. You are still able to adjust the mix level using the respective Mix knob; and this will become the maximum level when you sweep the pedal to its full position.

If your volume pedal continues to de-calibrate, or levels jump around when swept, it may be dirty and need replacing.

The Setup Menu: VLOOP Tab

Overview

Looping is a new feature for firmware version 1.3. The VLOOP tab offers control of new parameters required for looping. After the parameter descriptions below is a discussion of how to loop with VoiceLive 2.

UNDO

Turning this parameter to OFF doubles the amount of looping time available with the trade-off that you will not be able to undo the previous overdub. With the default setting of UNDO ON, you have 15 seconds of stereo looping or 30 seconds of mono. Stereo and mono output is configured in the I/O tab of the Setup menu.

LOOP FEEDBACK

This helps reduce audio overload when adding new recorded audio to a loop (“overdubbing”). It does so by reducing the level of each successive loop playback. The value is the multiplier of the previous playback in percent. A setting of 50% would sound like an echo unit where the echoes (loops) taper off audibly.

Using VLoop

VLoop allows you to create short, layered audio recordings on the fly. All analog audio inputs are recorded into the loop including Mic input, vocal effects, Guitar and Aux In. MIDI and USB inputs are not recorded. VoiceLive 2 is capable of one loop with as many layers as you want. Loops are erased during power off cycles.

Getting Ready

The SHORTCUT footswitch is used to initiate the looping features. You can assign it to LOOP in individual presets or globally. Your use depends on whether you require different Shortcut settings in different presets or not. If you do, then it's best to select a preset or presets whose effects would be useful for looping and assign their Shortcut to LOOP. This parameter is found under the PRESET tab in the Edit menu.

If you want looping available in all presets, set the GLOBAL SHORTCUT parameter in the SYSTEM tab of the Setup menu to LOOP. This will override all Shortcut

The Setup Menu: VLOOP Tab

settings previously assigned to your presets but it can be reversed later if needed.

After assigning the SHORTCUT footswitch, the Home display will show LOOP [STOP] in any presets in which it is assigned or all presets if LOOP is assigned globally. Rhythmic features are disabled when Loop is assigned.

Using Looping

All looping functions are done using one footswitch.

To make a new loop:

1. Assign the SHORTCUT footswitch to looping as discussed previously.
2. Tap SHORTCUT once on a downbeat of your music to start recording. Sing and/or play.
3. Tap SHORTCUT again (usually on a downbeat) to finish recording and play back your loop continuously. The display shows [PLAY].

To overdub another layer on your loop:

1. Tap SHORTCUT once during playback. Sing. Your new audio is added to the loop. You can layer continuously if you like. The display shows [O-DUB].

2. Tap SHORTCUT once to stop recording and continue playback. You can enter and exit overdubbing at any time during playback.

To undo the previous overdub:

1. Hold SHORTCUT during overdub or playback. This can be repeated to redo the overdub. A pop-up will show LOOP UNDO each time.

To stop loop playback:

1. Tap SHORTCUT twice quickly during playback to stop. This will briefly enter overdubbing so you should silence all inputs when stopping playback.

To erase your loop:

1. Hold SHORTCUT for a moment when stopped. A pop-up will show LOOP ERASED. This is not undo-able.

Overview

Pressing the Store button presents either the STORE or MANAGE tab depending on which was last used. In the STORE tab, turn the respective control to name presets and re-assign to other preset numbers. Navigate to the MANAGE tab to access useful preset functions listed below.

SEND PRESET TO MIDI SYSEX

Use this function to send an individual preset via MIDI for backup. Select the preset using any Mix/Edit knob. Push STORE to transmit.

ERASE USER PRESET

Use this function to erase an individual preset. If the preset is in a factory slot (1 to 205), this action will restore to the factory settings at the current preset location. Select the preset then set CONFIRM to YES using the 4th Mix/Edit knob, then push STORE.

CLEAN PRESET BANK (UP TO 2 MINUTES)

This function will run automatically on VoiceLive 2 when a large number of preset stores have been executed. To avoid this optimization sequence happening during performance, scroll to this item and press STORE to run the optimization routine. It takes approximately 2 minutes.

FAQ and Troubleshooting

My guitar doesn't change the harmonies.

Ensure your guitar is connected to the Guitar IN and not the THRU.

Turn up the volume control on your guitar.

Confirm your guitar cable is good by connecting your guitar directly to your amp.

Remove any guitar effect pedals between your guitar and VoiceLive 2's input.

Ensure that you are playing guitar chords made up of at least a root note and a major or minor third.

Ensure the NaturalPlay parameter in the HARMONY Edit menu is set to Auto or Guitar.

My guitar is connected to my amp but I can't hear it.

You may be in Tuner mode. Press the FX footswitch to hear your guitar.

Is your Shortcut assigned to Guitar Mute? If so press the SHORTCUT footswitch to hear your guitar.

My DELAY/REVERB MIX level is up but the sound is still dry

Turn on the Reverb and/or Delay effects with their respective footswitches.

If the effects are on, but you still don't hear the effect, make sure the sends are turned up for the effects. These parameters are located on the Reverb and Delay Edit menus.

How do I talk to my audience with no FX on?

Hold FX footswitch to enter Bypass + Tuner mode.

I'm using the Line input and the sound is distorted or I can't hear anything.

The LINE input shares the same input gain as the MIC input. You can use the automatic MIC GAIN setup procedure you used to set your Mic gain (ensure only the LINE input is connected) or you can set the gain manually in the I/O tab of the System menu.

FAQ and Troubleshooting

When I switch Phantom on and off the level changes. Why?

Because condenser microphones tend to have much higher output levels than a dynamic microphone, VoiceLive 2 stores different mic gain levels for when phantom power is on and off. The gain you set for your condenser mic is recalled when you turn Phantom on and an alternate gain is recalled for your dynamic mic.

Can I Use Alternate Tunings On My Guitar?

Alternate tunings e.g. drop D, DADGAD, etc. are okay. The most important notes of your chord, as far as VoiceLive 2 is concerned, are the chord root and the third, so make sure these notes are clearly voiced. Your guitar can be tuned to alternate tunings as long as you are in tune with the onboard tuner.

Why doesn't my keyboard change the harmonies?

If the MIDI light is not flashing when you play your MIDI device, then follow the steps for setting MIDI channel.

Check that the USB CONTROL parameter in the MIDI tab of the SETUP menu is OFF and remove the USB

cable.

If the MIDI light does flash, make sure no jack is connected to the GUITAR IN.

I don't hear my voice, only harmony and effects.

Make sure LEAD MUTE in the SYSTEM menu is set to "OFF". For any effect that is currently enabled, turn its LEAD MUTE parameter to OFF to hear your lead voice when the effect is on.

I'm not getting any sound out of VoiceLive 2

Confirm the power adapter is properly connected and power switch is in the on position.

Check the display meter when you sing to confirm the microphone and cable are good and that the level is set correctly.

Find out if your microphone needs phantom power and enable it if needed.

Make sure the Output level is turned up by turning one of the Mix/Edit knobs on the top screen.

FAQ and Troubleshooting

My corrected voice or harmony voice sounds out of tune

It's possible that the tuning reference of the instruments you are singing with are not tuned to the default setting of A=440. You can change the default tuning reference in the I/O tab of the SETUP menu.

My sound is distorted.

Press and hold the REVERB footswitch and follow the instructions for setting your mic gain.

If mic gain is set properly and the CLIP indicator is not blinking, turn down the OUTPUT setting on the mix screen or reduce the input level on your mixer channels.

I can't hear any Reverb or Delay

1. Check the top level mix screen and make sure the DELAY/REVERB level is turned up.
2. Confirm that the REVERB and/or DELAY footswitch is turned on as indicated by its footswitch light.
3. Confirm that the send levels are up for the Reverb and Delay block. To do this, press EDIT, navigate to the REVERB or DELAY tab, and scroll down to the Lead

and Harmony send parameters and make sure they are turned up.

4. If the send levels active are for the harmony voices, make sure the Harmony effect is turned on.

I can't hear any Harmony voices

1. Confirm that the Harmony effect is on by checking the HARMONY footswitch.
2. Check the top level mix by turning one of the knobs while on the home screen. Make sure the VOICES level is turned up.
3. If the name of the preset has NOTES in it, it's set to MIDI NOTES or MIDI NOTES 4 CH and will require you to play MIDI notes on the correct MIDI channel to produce harmonies.

I don't hear any audio from VoiceLive 2 when using MIC in

1. Check that the DIGITAL IN parameter in the Setup I/O tab is not set to USB VOX L / INST R or DIGITAL VOX L / INST R.
2. Check to see if there is level in the INPUT meter

FAQ and Troubleshooting

when singing. If not, check connection and run MIC GAIN setting procedure.

3. It's possible LEAD MUTE is enabled globally in the Setup I/O menu, set it to OFF to change.
4. Turn off all effects, one of the effects could have LEAD MUTE enabled.

I can't update my software

If USB is connected, check the USB CONTROL parameter under the SETUP / SYSTEM page. If it's set to OFF, VoiceSupport will not be able to connect to VoiceLive 2 and upgrade your software. When it's set to ON, you will be able to upgrade software but not be able to use a MIDI keyboard connected to the MIDI IN to control harmony.

MIDI Input doesn't work

See "I can't update my software" above.

My lead vocal is cutting out

1. Is the FX button on? Adjust the Transducer GATE THRESHOLD to a lower value in that preset.

2. If the Tone button is on, check that if the GATE is set to MANUAL, that the THRESHOLD is adjusted properly for your singing style.

The edit asterisk is always on in preset names

The LEAD MUTE parameter in the Setup I/O menu may be set to ON.

How can I reset everything?

To return all presets to factory settings, apply power while holding the Tone, Pitch and Guitar FX buttons. Note that this will permanently erase any user presets you have created.

To return all System settings to factory defaults, apply power while holding the Setup, Wizard and Store buttons.

Where can I find support for this product?

There are three easy ways to get support:

1. Install the VoiceSupport application
2. Visit www.tc-helicon.com/support
3. Email support@tc-helicon.com

MIDI Implementation

	Parameter	CC#	Range	Comments
Footswitch	On/Off			
	Harmony	110	0-63 off 64-127 on	
	Double	111	" "	
	Reverb	112	" "	
	HardTune	113	" "	FX button must be active first
	Step	115	0 to the # of steps in preset	0=Step 1, 1=Step 2 etc.
	μMod	116	0-63 off 64-127 on	
	Delay	117	" "	
	Trans	118	" "	FX button must be active first
	FX	104	" "	On sets HardTune and Transducer to preset on/off status
Block Edits				
μMod	Style	50	0-24	
	Level	90	0-127	
Delay	Style	51	0-12	
	Level	62	0-127	
Reverb	Style	52	0-30	
	Level	91	0-127	
Double	Style	53	0-5	
	Level	15	0-127	
Transducer	Style	55	0-15	
	Out Gain	105	0-127	
Harmony	Style	56	0 to the # of styles available	Only for NaturalPlay, Scale and Shift modes. N/A for Notes, Notes 4Chan.
	Level	12	0-127	
	Harmony Key	30	0-11	0=C, 1=C#, 2=D, 3=Eb, 4=E, 5=F, 6=F#, 7=G, 8=G#, 9=A, 10=Bb, 11=B
	Harmony Scale	31	0-6	0=Maj1, 1=Maj2, 2=Maj3, 3=Min1, 4=Min2, 5=Min3, 6=Custom Scale
	Voicing Voice1	89	0 to the # of voicings in mode	N/A for Notes and Notes 4 Chan modes
	Voicing Voice2	61	" "	" "
	Voicing Voice3	88	" "	" "
	Voicing Voice4	3	" "	" "
	Level Voice1	46	maps to 127 values	

MIDI Implementation

	Parameter	CC#	Range	Comments
	Level Voice2	17	" "	
	Level Voice3	21	" "	
	Level Voice4	25	maps to 127	
	Gender Voice1	29	" "	
	Gender Voice2	19	" "	
	Gender Voice3	23	" "	
	Gender Voice4	27	" "	
	Human Style	16	0-6	
	Human Lvl	20	maps to 127	
	Vib Style	24	0-7	
	Vib Amt	1	maps to 127	Vib Style must not be 0
	Doubling Lvl	35	" "	0=Doubling off, 1-127 mapped to parm values
	Choir Lvl	72	" "	0=Choir off, 1-127 mapped to parm values
	Choir Style	73	0-14	
HardTune	Key	47	0-11	0=C, 1=C# etc. Sending any value de-activates Follow Harmony
	Scale	48	0-5	0=Major, 1=Minor-Har, 2=Minor-Nat, 3=Minor-Asc, 4=Chromatic, 5=Custom
	Rate	54	0-127	
	Amount	57	maps to 127	
	Window	49	" "	
Globals	Tone	106	0-63 off 64-127 on	On/Off only
	Pitch	107	maps to 127	0=off
	Guitar FX	108	0-63 off 64-127 on	On/Off only
	Guitar Level	109	maps to 127	
	Guitar Rev Style	9	0 to the # of styles available	
	Guitar Rev Lvl	22	maps to 127	
	Guitar Mod Style	26	0 to the # of styles available	
	Guitar Mod Lvl	28	maps to 127	
System	Lead Mute	13	0-1	0=off, 1=on
	Voices Level	85	maps to 127	

MIDI Implementation

Parameter	CC#	Range	Comments
Delay/Reverb Lvl	86	" "	
Dry Pan	10	" "	127 MIDI values map to 201 pan values, Center = 64
Output Level	7	" "	
Bypass	114	0-63 off 64-127 on	Bypass only, no tuner mode. FX button is not lit in this Bypass
Harmony Hold	119	" "	
Sustain	64	" "	Active in MIDI Naturalplay and MIDI Notes, MIDI Notes 4 Chan modes.
Aux Level	58	Maps to 127	
All Notes Off	123	" "	

Non-CC messages

Pitch Bend			
MIDI Clock			Active when Delay tempo set to MIDI
Bank select	0-3		Presets 1-128=Bank 0, 129-256=Bank 1, 257-384=Bank 2, 384-400=Bank 3
Preset select	0-127		0=preset #1, 1=preset #2 etc.
MIDI Notes			

Factory Preset List

1	SIXTH ENCORE	26	SIMPLE SLAP	51	JAZZ CLOSEUP 2	76	SING WITH RADIO
2	CLOSE UP 3RD	27	LONGVERB DUCKED	52	JAZZ CLOSEUP 3	77	THICK 2 ABOVE
3	TUNED UP+DOWN	28	ARENA CHANT	53	LIGHT FLANGE	78	BEACH BOY RADIO
4	KANYE LOCKDOWN	29	AMATEUR KIDS	54	LOWER DUO	79	TOE PLASTIC
5	ANOTHER BRICK	30	PRO KIDS	55	LOWER & DOUBLE	80	3RDS & 5THS BIG
6	BRIGHT DOUBLE	31	CLOSE 1UP+1DOWN	56	DARK SWIRL	81	HIGHERCHOIR WET
7	TWO HIGH	32	CLOSE BELOW	57	TWO LOW	82	BASSY CHOIR
8	CHORALE THREE	33	3RD OCT BELOW	58	CHORALE ONE	83	CHANGE THE WORL
9	UNISON CHOIR	34	3RDS & 5THS L-R	59	CHORALE TWO	84	BIG BOTTM CHOIR
10	AUTOTUNE RADIO	35	FAR 1UP+1DOWN	60	3RD UP GROUP	85	3RD UP CHOIR
11	DEEPER YOU	36	FAR GENDERS	61	3RD UP LADIES	86	4TH DOWN CHOIR
12	POWER CHORDS 2	37	2UP+1DOWN	62	LOWER GUYS	87	6TH DOWN CHOIR
13	HIGHER CHOIR	38	1UP+2DOWN	63	FAR GENDRGROUP	88	YOU'RE NOT ALON
14	HARMONY CHOIR	39	2UP+1DOWN+OCT	64	1UP+2DOWN+OCT	89	U R ALTO
15	RADIOHARMNY DLY	40	SHIFT -4 SEMI	65	DOMINUS REQUIEM	90	U R SOPRANO
16	BASS & 3RD UP	41	SHIFT +5 SEMI	66	FADEOUT 3RD UP	91	TUNED HARMONY
17	ELVIS RADIO	42	ONE UP ROOM	67	STEVE MCQUEEN	92	TUNED 2UP
18	DOUBLE REFLECT	43	CHOIR ONE	68	UP TWO ROOM	93	TUNED 1 BELOW
19	ANGELS RADIO	44	LOWER TRIO	69	SLAP ABOVE	94	LOWER ROBOTS
20	DIGERI-VOICES	45	BASSMAN	70	SLAP TRIO	95	UPPER ROBOTS
21	DISTORTO	46	COUNTRY GIRLS	71	BASS & LOW	96	RADIO GOSPEL
22	POP DUO	47	POP TRIO	72	3UP FLANG DELAY	97	JAZZ RADIO
23	LOWER BACKUP	48	STEREO PAIR 3+5	73	RUNNING ON MT	98	FLANGY 3RD
24	THE MASSES	49	6TH BELOW	74	FLANGE TWO HIGH	99	POWER CORDS
25	DEEP DOWN	50	JAZZ CLOSEUP	75	FLANGE UP & DN	100	HARD TUNE DELAY

Factory Preset List

101	DELAYED UPPERS	128	LOOSE DOUBLE	155	BANDPASS VERB	182	BOLLYWOOD
102	DELAYED HARMONY	129	OCTAVE CHILD	156	DEEP DUCKED FX	183	NOW HEAR THIS!
103	LIFE IN THE F L	130	BON J-U GIVE LV	157	T- ROOM	184	BASIC NOTES 8V
104	TONE DRONE UNI	131	OCT DOWN DOUBLE	158	ALTERNATIVE	185	NOTES 1V FEMALE
105	UNI+5TH DRONES	132	OCT DOWN GROUP	159	THICK OVERDRIVE	186	EASY NOTES 8V
106	OCTAVE DRONE	133	HARDTUNE OCTAVS	160	MEDIUM CORR 20%	187	NATURAL NOTES
107	TONE DRONE DOWN	134	GREGORIAN	161	GENTLE CORR 10%	188	NOTES 1V MELODY
108	TONE DRONE UP	135	SILKY DOUBLES	162	EASYTUNE	189	NOTES 1V MALE
109	DIGERI-DISTORT	136	CRUNCH DETUNE	163	T-PAINFUL	190	NOTES UNI STACK
110	MICROPITCH	137	OCTAVE FLANGE	164	STAGE AMP	191	NOTES UNI + YOU
111	DOUBLE CHORUS	138	VALKYRIE DUO	165	ECHO DOWN	192	THICK NOTES 4V
112	CHORUS PLATE	139	METAL DEMONS	166	IN THE SEWERS	193	NOTES 8V WIDE
113	DOUBLE BALLAD	140	SPACE CHOIR	167	POLTERGEIST	194	NOTES 8V MALES
114	OVERDUB SLAP	141	MONO SPRING	168	CHURCH TUNE	195	NOTES 8V FEMALE
115	100% WET UNISON	142	SMOOTHED VERB	169	AUTO PANNER	196	NOTES SLOW ATK
116	LAGER & ALE	143	GORGEOUS HALL	170	I AM A WALRUS	197	NOTES HEAVEN
117	MIXED OCTAVES	144	PRACTICE ROOM	171	POWER CORD ECHO	198	NOTES HEAVEN 2
118	OCT UP DOUBLE	145	JUST AMBIENCE	172	FLUTTER	199	NOTES 1V VOCODR
119	OCT UP GROUP	146	SLAP DUCK	173	CYLON DRONE	200	VOCODER SHIMMER
120	THINNER YOU	147	HOT SLAP	174	CLOCK RADIO	201	VOCO PORTA DIST
121	POPEYE + OLIVE	148	FREE FALLING	175	DISTORTED RADIO	202	NOTES WET CHOIR
122	OCTAVE POP	149	SIMPLE CHORUS	176	DIRTY SCREAM	203	NOTES CHOIR MEN
123	FIFTH DIVA	150	IF I WERE ABOY	177	TRASH-IT	204	NOTES CHOIR FEM
124	UNISON F&M	151	DUCKING TAPS	178	OCTAVE TRASH	205	NOTES CHOIR+UNI
125	UNISON M&F	152	MOD DELAY	179	ROTARY STEP F/S		
126	PANNED DOUBLES	153	DIST DELAY	180	CHAOS		
127	MASSIVE STACK	154	TUNE TRANS ECHO	181	SPIRAL DOWN		

Effects Path Diagram

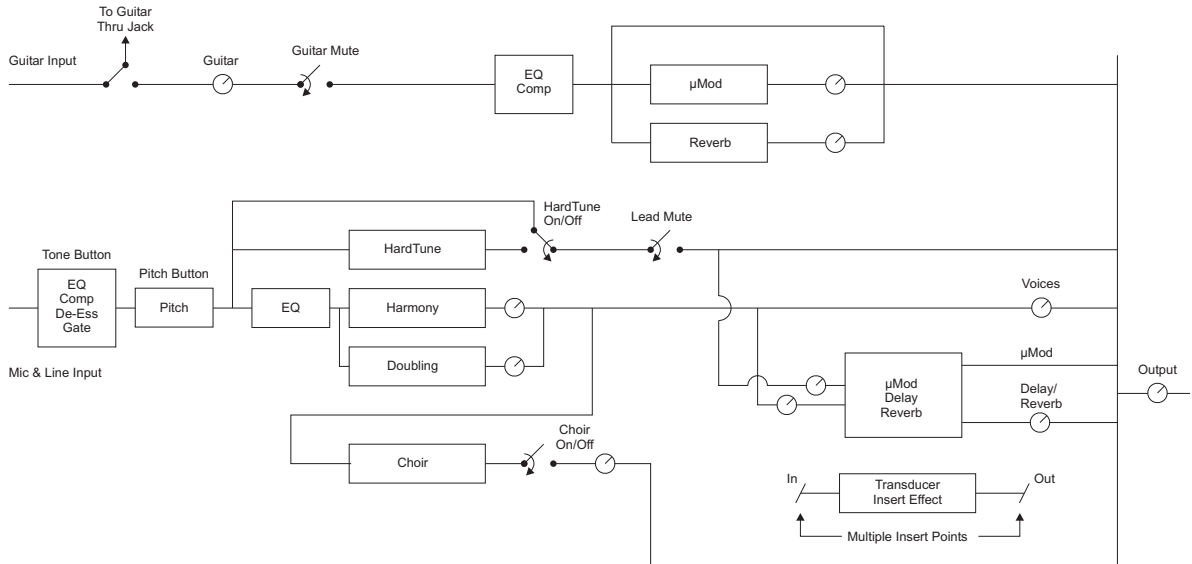

Warranty

All products manufactured by TC-Helicon are warranted against failure arising through faulty workmanship and materials for a period of one year from date of purchase.

All claims under this warranty must be made to the distributor in the buyer's country (in many cases the distributor is TC-Helicon's parent company TC Group), by returning the unit, securely packed, postage prepaid and insured, with an enclosed note, describing the symptoms. Within the warranty period, the unit will be repaired at no charge for parts and labor.

This warranty remains valid only if the serial number on the unit has not been defaced or removed, and if repairs are performed only by the distributor or TC Group company. It does not cover damage due to misuse, accident or neglect. Distributor and TC-Helicon retains the exclusive right to make such determinations on the basis of inspection.

Liability is expressly excluded in respect of any third party or consequential loss or damage (direct or indirect) however or whenever arising. This warranty gives you specific legal rights. You may also have others, which vary from country to country.

Specifications

Analog Inputs

Connectors, balanced	Mic.: XLR, Line: 1/4" phone jack, Guitar: 1/4" phone jack, Aux: 1/8" stereo mini jack
Input Impedance: Bal./Unbal.	Mic.: 2.14/1.07 kOhm, Line: 13/6.5 kOhm
Mic Input Level @ 0 dBFS	-49dBu to +10dBu
Line Input Level @ -37 dBu to +22 dBu	-37 dBu to +22 dBu
EIN @ Max Mic Gain Rg = 150 Ohm	-126 dBu
Mic/Line Input SNR	> 107 dB
Guitar Input impedance	1 MOhm
Guitar Input Level @ 0 dBFS	14 dBu to -4 dBu
Guitar Input SNR	>104dB
Aux Input Level @ 0dBu	+2dBu
A to D Conversion	24 bit, 128 x oversampling bit stream via S/PDIF, 16 bit via USB, 110dB SNR A-weighted.

Analog Outputs

D to A Conversion	24 bit, 128 x oversampling bit stream via S/PDIF, 16 bit via USB, 115dB SNR A-weighted
Connectors, balanced	XLR and 1/4" phone jack
Output Impedance Bal./ Unbal.	100/50 Ohm
Output Range (Line/Mic Level)	16 dBu / 0dBu
Dynamic Range	> 109 dB, 20 Hz to 20 kHz
Frequency Response	+0/-0.3 dB, 20 Hz to 20 kHz
Headphone Out	1/8" Mini stereo jack, 32 Ohm, +16dBu max (180mW max)

Digital Inputs and Outputs

Connectors	RCA Phono (S/PDIF)
Formats	S/PDIF (24 bit), EIAJ CP-340, IEC 958
Sample Rates	44.1 kHz, 48 kHz, 88.2kHz, 96kHz
EMC	
Complies with	EN 55103-1 and EN 55103-2 FCC part 15, Class B, CISPR 22, Class B
Safety	
Certified to	IEC 65, EN 60065, UL6500 and CSA
Environment	
Operating Temperature	32° F to 122° F (0° C to 50° C)
Storage Temperature	-22° F to 167° F (-30° C to 70° C)
Humidity	Max. 90 % non-condensing
Control Interface	
USB	USB-B
MIDI	In/Out/Thru: 5 Pin DIN
Pedal	1/4" TRS phone jack
Supplementary	
Display	192 x 64 Blue STN LCD, White Back light
Dimensions	13.8" x 3" x 8.5" (350 x 76 x 216)
Weight	5 lb. (2.3 kg)
External Power Supply Mains Voltage	100 to 240 VAC, 50 to 60 Hz (auto-select)
Power Consumption	<14 W

Technical specifications are subject to change without notice

